

- Timing with germanium detectors
- Energy spectroscopy at ultra-high count rates
- Selectable filter for pulse shaping
- Signal-to-noise ratio optimization
- Continuously adjustable gain, X2 to X250
- Pole-zero cancellation
- DC-coupling



The ORTEC Model 474 Timing Filter Amplifier is especially designed to shape pulses and permit optimizing the signal-to-noise ratio for timing measurements. The Model 474 is particularly suited for use with an ORTEC Constant-Fraction Timing Discriminator in timing applications with germanium or silicon charged-particle detectors (Fig. 1). It derives its input signal directly from the preamplifier output. The timing spectrum in Fig. 2 illustrates the performance obtainable with the Model 474 shaping the germanium detector pulses before they are furnished to the discriminator. Tables 1 and 2 give typical performance data for various ORTEC germanium detectors.

The fast rise time, high output drive, and high gain capabilities of the Model 474 make it useful for other applications, such as timing with systems utilizing low-gain photomultiplier tubes. In addition, the pole-zero cancellation network, the dc-coupling, and the time-invariant baseline restorer permit energy spectroscopy with scintillation detectors and Si charged-particle detectors at ultra-high count rates.

A wide variety of input pulse shapes can be filtered as required for optimum signal processing. The Model 474 combines continuously adjustable gain (X2 to X250) with separately selectable Integrate (τ_i) and Differentiate (τ_d) time constants for proper pulse shaping, making this unit an important asset for time measurement.

Specifications

PERFORMANCE

INPUT AMPLITUDE RANGE 0 to ± 1 V signal, 0 to ± 5 V dc offset; maximum input ± 5 V total.

OUTPUT AMPLITUDE RANGE 0 to ± 5 V with a 50- Ω load.

NOISE For maximum gain, rms noise referred to the input is ≤ 10 μ V with $\tau_i = \tau_d = 200$ ns or ≤ 50 μ V with filter out; measured using a Hewlett-Packard 3400A true rms meter.

RISE TIME ≤ 10 ns with filter Out or $\sim 2.2 \tau_i$ for other selections.

NONLINEARITY $\leq \pm 0.05\%$ at midband frequency over ± 5 V range.

TEMPERATURE INSTABILITY

DC Level $\leq \pm 25$ μ V/ $^{\circ}$ C referred to the output.

Gain $\leq \pm 0.06\%/^{\circ}$ C.

Specifications over 0 to 50 $^{\circ}$ C range.

CONTROLS

COARSE GAIN Front-panel 6-position switch for selection of X1, X2, X4, X6, X10, or X20.

FINE GAIN Front-panel single-turn potentiometer, continuous from X2 to X12.5.

POLE ZERO ADJ Front-panel screwdriver adjustment to compensate for the preamplifier decay time constant.

TIME CONSTANT Two 6-position switches on front panel:

Integrate RC time constants: Out (equivalent to 4 ns), 20, 50, 100, 200, and 500 ns.

Differentiate RC time constants: Out (equivalent to 0.2 ms), 20, 50, 100, 200, and 500 ns.

NOTE: With Differentiate and Integrate in the Out position, the passband is 1 kHz to 35 MHz.

NON INV/INV Selects inversion or non-inversion of the input signal.

INPUT

Positive or negative polarity selectable by front-panel switch; amplitude 0 to ± 1 V; protected to ± 6 V dc and to ± 100 V at 10% duty factor integrated over 1 s; impedance 100 Ω , dc-coupled; front-panel BNC connector. Accepts a ± 5 V dc offset, maximum input (signal plus offset) limited to ± 5 V.

OUTPUTS

OUTPUT Front-panel BNC connector. Amplitude 0 to ± 5 V; rise time ≤ 10 ns for filter out ($2.2 \tau_i$ for other filter selections). Impedance $< 1 \Omega$, dc-coupled.

PREAMPLIFIER POWER Rear-panel standard ORTEC power connector, Amphenol 17-10090.

ELECTRICAL AND MECHANICAL

POWER REQUIRED +24 V, 65 mA; -24 V, 45 mA; +12 V, 160 mA; -12 V, 180 mA.

WEIGHT

Net 1.0 kg (2.4 lb).

Shipping 2.5 kg (5.4 lb).

DIMENSIONS NIM-standard single-width module 3.43 X 22.13 cm (1.35 X 8.714 in.) per DOE/ER-0457T.

Ordering Information

To order, specify:

Model	Description
474	Timing Filter Amplifier

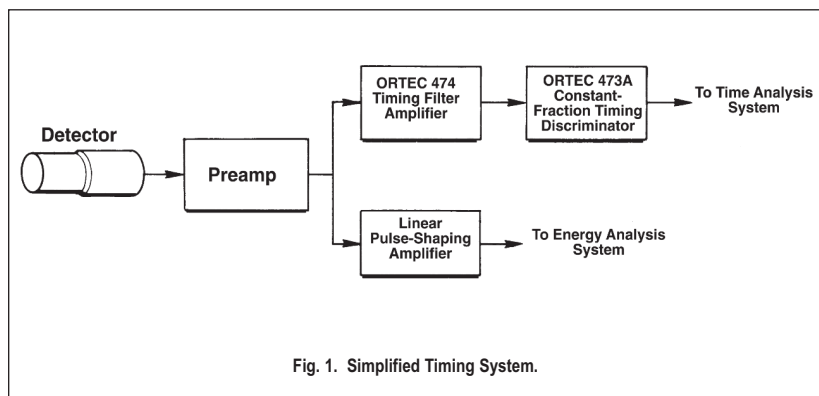

Fig. 1. Simplified Timing System.

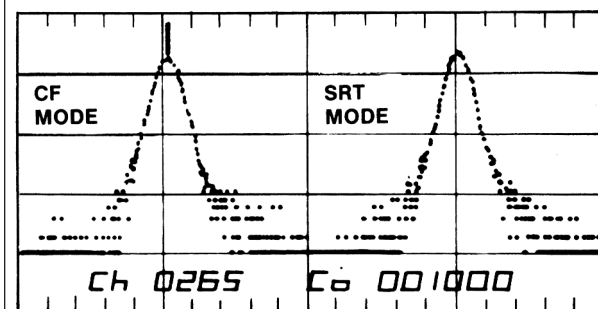

Fig. 2. Timing Spectrum for a Narrow Dynamic Range Using a Germanium Detector. (Resolution values are given in Table 1.)

²²Na
 Start: KL236 (1 X 1), RCA 8575 Photomultiplier Tube
 Stop: Ge Coax, 12.5%, 62.3 cc
 1.1:1 Dynamic Range
 473A Discriminator

Table 1. Timing Resolution for Various Sizes of Germanium Detectors Using ²²Na.

Detector	Dynamic Range	Timing Resolution (ns)						
		CF Mode			SRT Mode			
		FWHM	FW.1M	FW.02M	FWHM	FW.1M	FW.02M	FW.01M
8.6% HPGe 52.6 cc	1.1:1	4.4	10.1		4.3	10.1		21.6
	10:1	4.2	13.6		4.2	10.5		23.4
	20:1	4.7	13.5		4.7	12.8		30.4
12.5% HPGe 62.3 cc	1.1:1	5.0	10.0		5.0	9.5		17.6
	10:1	4.5	13.2		4.4	9.4		17.8
	20:1	5.1	14.3		5.0	12.0		24.8
19.6% HPGe 103 cc	1.1:1	7.9	16.4		8.1	16.0		27.3
	10:1	8.4	24.0		7.9	17.0		30.0
	20:1	8.4	26.0		8.4	23.0		40.0
8.6% HPGe	1.1:1	6.4	12.6	29.1	6.5	14.1	29.6	
	5:1	7.6	18.0	59.4	7.3	18.0	45.6	
	10:1	7.6	22.7	63.2	7.6	21.7	50.1	

Table 2. Timing Resolution for Large Germanium Detectors Using 583 CFDD/SCA, 474 TFA, and ⁶⁰Co.

Detector	Efficiency	FWHM Energy Resolution (keV)	Constant Fraction Delay (ns)	Timing Resolution (ns)			
				E > 100 keV		E = 1332 ±50 keV	
				FWHM	FW.1M	FWHM	FW.1M
N30526A	73%	2.03	34	5.4	19.4	3.7	8.8
P20171	81%	1.97	34	5.5	27.0	4.7	13.8
N20366A	88%	2.34	36	5.8	21.2	5.5	16.4



Specifications subject to change
072720