

- Dual purpose: High-rate and low-rate energy spectroscopy with Ge detectors
- Both Semi-Gaussian and Gated Integrator outputs
- Gated Integrator compensates for charge collection time variations in Ge detectors for improved energy resolution and throughput at high counting rates
- Semi-Gaussian output offers optimum resolution at low counting rates
- Shaping time constants from 0.25 to 6 μ s
- Built-in gated BLR and pile-up rejector



The ORTEC Model 673 Spectroscopy Amplifier and Gated Integrator is a dual purpose amplifier for high-resolution energy spectroscopy with germanium detectors at both low and high counting rates. In addition to a conventional, semi-Gaussian shaping amplifier, the Model 673 includes a Gated Integrator to achieve excellent energy resolution at high throughputs.¹ The UNIPOLAR output of the semi-Gaussian amplifier is identical to the ORTEC Model 572, except that the shaping time constants range from 0.25 to 6 μ s. The longer shaping time constants on this output provide the best energy resolution at low counting rates.

At high counting rates, short shaping time constants are necessary to achieve high throughput. Normally, the charge collection time variations in the Ge detector would severely degrade the energy resolution at such short time constants (Fig. 1a). The Gated Integrator solves this problem (Fig. 1b) by integrating the area under the unipolar pulse and by setting an integration period that ensures complete integration of the longer pulses that result from slower charge collection in the Ge detector (Figs. 2 and 3). The result is significantly improved energy resolution (Figs. 1b and 4) at a throughput that is approximately four times the maximum counting rate achievable with conventional semi-Gaussian shaping (Fig. 5). The Model 673 Gated Integrator output can maintain excellent resolution and peak position stability to a much higher counting rate than is feasible with semi-Gaussian shaping (Figs. 6 and 7).

A pile-up rejector is included to minimize the spectral distortion caused by two or more photons arriving at the detector within one amplifier pulse width. The pile-up rejector connects to the anti-coincidence gate of a multichannel analyzer, and provides protection for either the UNIPOLAR or the Gated Integrator output. A front-panel switch allows either manual or automatic adjustment of the noise threshold for the pile-up rejector and the baseline restorer. The manual mode is useful for transistor reset preamplifiers.

The Model 673 accommodates both resistive feedback preamplifiers and transistor reset preamplifiers (TRP). With transistor reset preamplifiers a logic pulse derived from the preamplifier reset signal can be provided to the GATE INPUT of the Model 673 for the duration of the overload caused by the preamplifier reset. The GATE INPUT is "ORed" with the pile-up rejector signal at the GI INH output and is used by the multichannel analyzer to prevent the analysis of pulses distorted by the reset.

The UNIPOLAR output also functions as a high-performance semi-Gaussian shaping amplifier that can be used with a variety of detector types, including germanium detectors, silicon charged-particle detectors, Si(Li) detectors, proportional counters, and scintillation detectors.

Specifications

PERFORMANCE

GAIN RANGE Continuously adjustable, X1 through X1500.

UNIPOLAR PULSE SHAPING Unipolar, Gaussian on all ranges with peaking time equal to 2.2τ and pulse width at 0.1% level, equal to 2.9 times the peaking time.

GI PULSE SHAPING Time variant gated integrator.

INTEGRAL NONLINEARITY $<\pm 0.05\%$ (0.025% typical) at the unipolar output using 2- μ s shaping.

NOISE $<4 \mu$ V referred to the input using 3- μ s shaping; gain >100 , unipolar output.

TEMPERATURE INSTABILITY (Unipolar Output)

Gain $\leq \pm 0.0075\%/^{\circ}\text{C}$, 0 to 50 $^{\circ}\text{C}$.

DC Level $<\pm 10 \mu$ V/ $^{\circ}\text{C}$, 0 to 50 $^{\circ}\text{C}$.

UNIPOLAR COUNT RATE INSTABILITY The 1.33-MeV gamma-ray peak from a ^{60}Co source, positioned at 85% of analyzer range, typically shifts $<0.024\%$, and its FWHM broadens $<14\%$ when its incoming count rate changes from 0 to 100,000 counts/s using 2- μ s shaping. The amplifier will hold the baseline reference up to count rates in excess of 150,000 counts/s.

¹T.H. Becker, E.E. Gross, R.C. Trammell, "Characteristics of High-Rate Energy Spectroscopy Systems with Time-Invariant Filters," *IEEE Trans. Nucl. Sci.*, NS-28, 598 (1981).

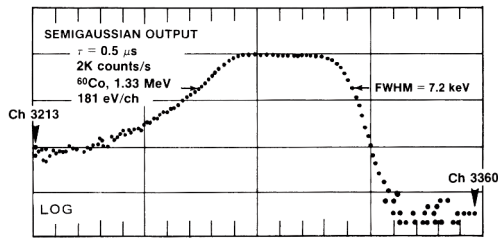

Fig. 1a. Energy Resolution with Semi-Gaussian Shaping and a 0.5 μs Shaping Time Constant. Maximum throughput capability is the same as for Fig. 4.

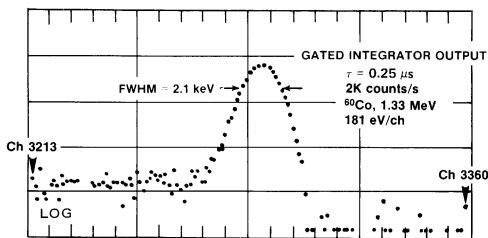

Fig. 1b. Energy Resolution at the Gated Integrator Output with a 0.25 μs Shaping Time Constant.

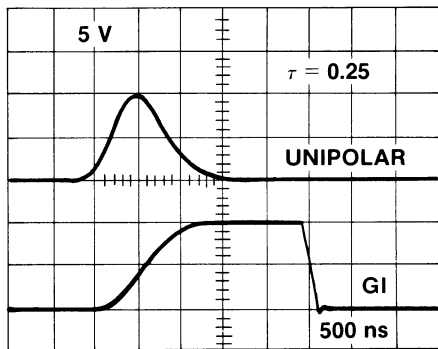

Fig. 2. Gated Integrator (GI) Output and Unipolar Output.

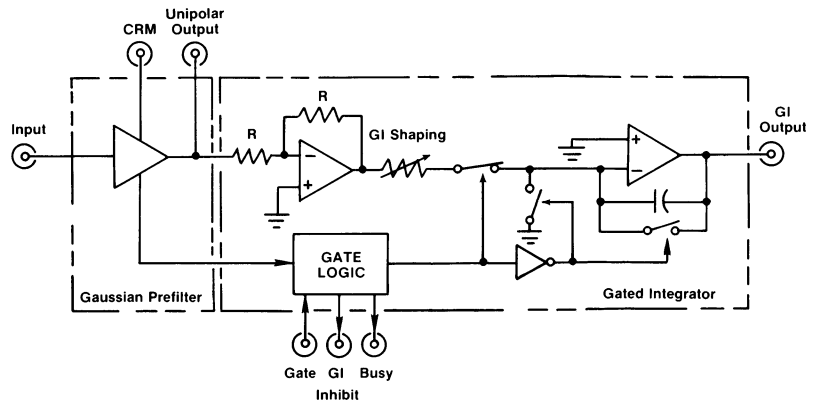

Fig. 3. Simplified Block Diagram of the Model 673 Spectroscopy Amplifier and Gated Integrator.

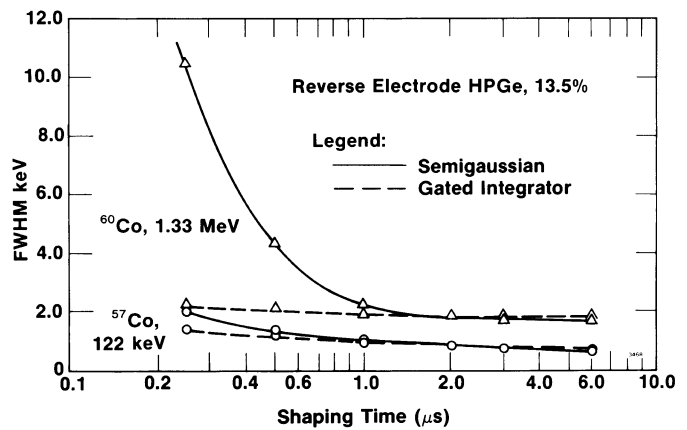

Fig. 4. Resolution as a Function of Shaping Time Constant for Semi-Gaussian and Gated Integrator Pulse Shaping.

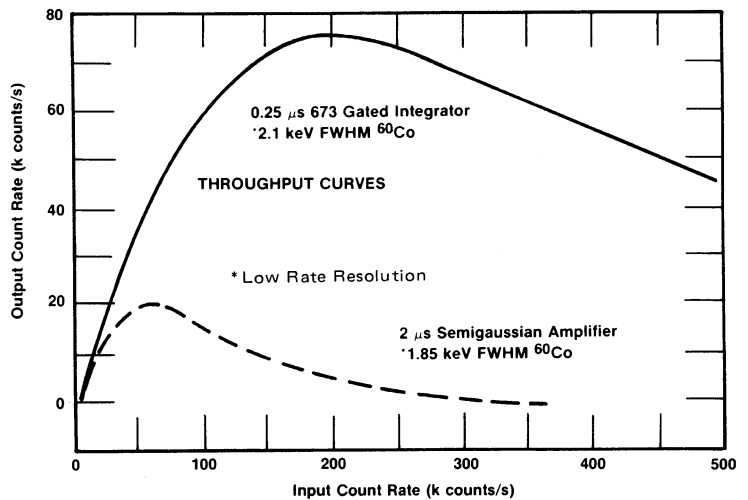

Fig. 5. Example of the Throughput Improvement Using the Gated Integrator Technique.

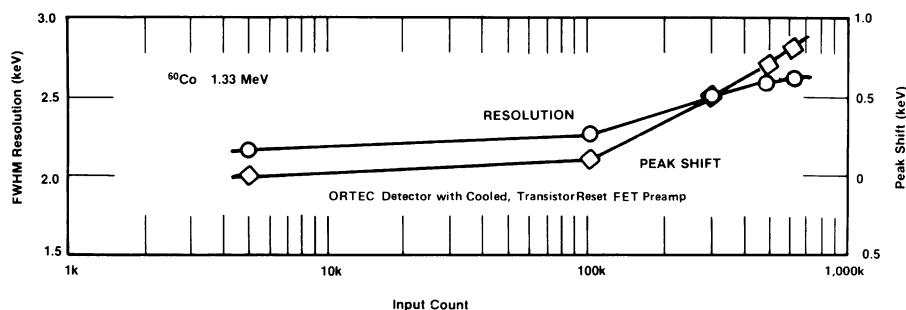

Fig. 6. Resolution and Baseline Stability vs Counting Rate for the GI Output of the Model 673 Using 0.25- μ s Shaping Time, Measured on a 10% Relative Efficiency GMX Detector.

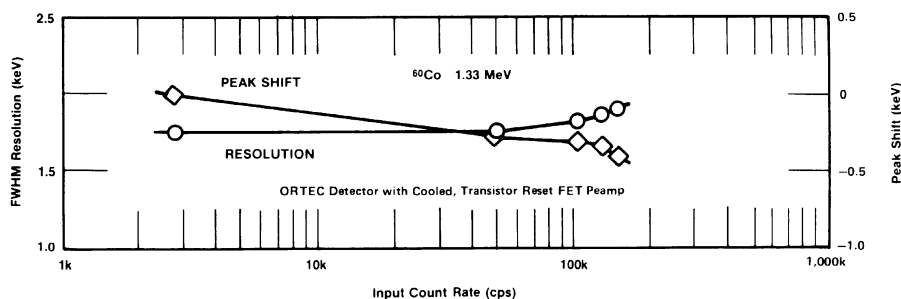

Fig. 7. Resolution and Baseline Stability vs Counting Rate for the Unipolar (Semi-Gaussian) Output of the Model 673 Using 2- μ s Shaping Time, Measured on a 10% Relative Efficiency GMX Detector.

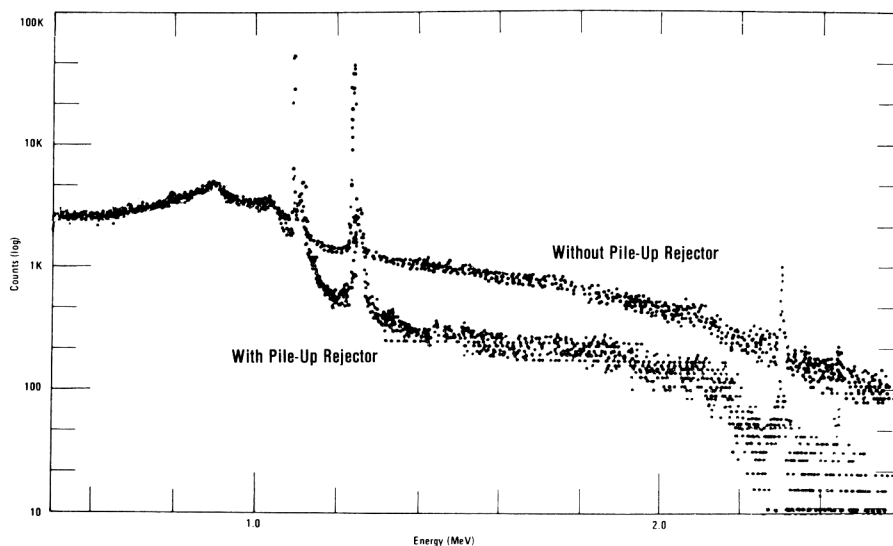

Fig. 8. Background Reduction Obtained from Pile-Up Rejection.

GI THROUGHPUT AND RESOLUTION The Gated Integrator allows operation at short time constants, which permits higher throughput rates while maintaining excellent resolution. Typical results for a 10% HPGe detector with transistor-reset preamplifier using a ^{60}Co source and 200,000 counts/s input:

Output	Time Constant	Dead Time	Max. Throughput	Resolution
Unipolar	0.5 μ s	5 μ s	74k c/s	7.5 keV
GI	0.25 μ s	5 μ s	74k c/s	2.3 keV

OVERLOAD RECOVERY Unipolar output recovers to within 2% of rated output from X300 overload in 2.5 nonoverloaded unipolar pulse widths, using maximum gain.

CONTROLS

FINE GAIN Ten-turn precision potentiometer for continuously variable direct-reading gain factor of X0.5 to X1.5.

COARSE GAIN Six-position switch selects feedback resistors for gain factors of 20, 50, 100, 200, 500, and 1k.

INPUT ATTENUATOR Jumper on printed wiring board selects an input attenuation factor of 1 to 10 (gain factor of X1 or X0.1).

POS/NEG Toggle switch selects Pos or Neg input.

SHAPING TIME Two six-position switches select the time constant for active-filter-network pulse shaping; selections are 0.25, 0.5, 1, 2, 3, and 6. Switch settings should be set equally for normal operation.

PZ Two potentiometers to adjust pole-zero cancellation for decay times from 40 μ s to ∞ . Fine PZ corresponds to approximately 10% of coarse PZ.

BLR Toggle switch selects a source for the gated baseline restorer discriminator threshold level from one of three positions:

Auto The BLR threshold is automatically set to an optimum level as a function of the signal noise level by an internal circuit. This allows easy setup and very good performance.

PZ Adj The BLR threshold is determined by the threshold potentiometer. The BLR time constant is greatly increased to facilitate PZ adjustment. This position may give the lowest noise for conditions of low count rate and/or longer shaping times.

Threshold The BLR threshold is set manually by the threshold potentiometer. Range, 0 to 300 mV referred to the positive output signal. The BLR time constant is the same as for the Auto switch setting.

DC Screwdriver potentiometer adjusts the unipolar output baseline dc level; range, +100 mV to -100 mV. Adjust to 0 for proper Gated Integrator operation.

INPUTS

LINEAR Positive or negative signal through either front- or rear-panel BNC connectors. Accepts pulses with rise times in the range from 10 to 650 ns and decay times from 40 to 2000 μ s; $Z_{in} \cong 1$ k Ω , dc-coupled; linear maximum 1 V (10 V with attenuator jumper set at X0.1); absolute maximum 20 V.

GATE Rear-panel BNC connector accepts standard positive NIM signal to produce a pile-up reject signal at the GI INH output during the reset interval of a pulsed-reset preamplifier. Input polarity selectable with printed wiring board jumper.

OUTPUTS

UNI Front-panel BNC with $Z_o < 1$ Ω and rear-panel BNC with $Z_o = 93$ Ω . Short-circuit proof; full-scale linear range 0 to +10 V; active-filter-shaped and dc-restored; dc level adjustable to ± 100 mV.

GI Front-panel BNC with $Z_o < 1$ Ω and rear-panel BNC with $Z_o = 93$ Ω . Short-circuit proof; full-scale range 0 to +10 V; dc level 0 ± 5 mV.

BUSY Rear-panel BNC with $Z_o < 10$ Ω provides a +5 V logic pulse for the duration that the input pulse exceeds the baseline restorer discriminator level. Connects to the ORTEC MCA Busy Input for dead time correction.

UNI INH Rear-panel BNC with $Z_o < 10$ Ω provides a nominal +5 V logic signal when an internal pulse pile-up occurs; to be used for an MCA anticoincidence input to prevent storage of pile-up data in the spectrum when using the unipolar output.

GI INH Rear-panel BNC with $Z_o < 10$ Ω provides a nominal +5 V logic signal when an internal pulse pile-up occurs; to be used for an MCA anticoincidence input to prevent storage of pile-up data in the spectrum when using the GI output. PWB polarity selection. (Shipped in positive position).

CRM (Count Ratemeter) Rear-panel BNC furnishes a nominal +5 V logic signal for every linear input pulse; width 300 ns; to be used as an input to a ratemeter or counter.

ELECTRICAL AND MECHANICAL

PREAMP POWER Rear-panel standard ORTEC power connector; Amphenol 17-10090; mates with captive and noncaptive power cords on all standard ORTEC preamplifiers.

POWER REQUIRED +24 V, 125 mA; -24 V, 105 mA; +12 V, 150 mA; -12 V, 75 mA.

WEIGHT

Net 1.4 kg (3 lb).

Shipping 3.2 kg (7 lb).

DIMENSIONS NIM-standard double-width module 6.90 X 22.13 cm (2.70 X 8.714 in.) front panel per DOE/ER-0457T.

Ordering Information

To order, specify:

Model	Description
673	Spectroscopy Amplifier and Gated Integrator

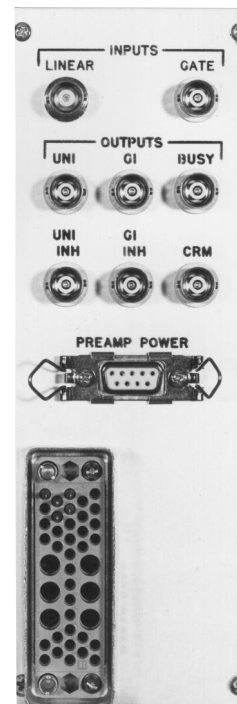

Specifications subject to change
102920

ORTEC[®]

www.ortec-online.com

Tel. (865) 482-4411 • Fax (865) 483-0396 • ortec.info@ametek.com
801 South Illinois Ave., Oak Ridge, TN 37830 U.S.A.
For International Office Locations, Visit Our Website

AMETEK[®]