

- For routine alpha/beta counting
- Convenient and durable
- Sample-to-detector distance easily set and measured
- Can be used for beta-gamma coincidence measurements
- Single valve for pumping and venting



The ORTEC Model 807 Vacuum Chamber is designed for routine alpha/beta counting applications using a semiconductor radiation detector and a radioactive sample. Two examples of the many applications possible with this convenient and durable chamber are its use in educational laboratories to demonstrate detectors and counting principles, and in radiological laboratories for smear counting.

The detector is mounted in the center of the chamber cover, and the sample is mounted on one of three support rods at a preselected distance from the detector. This design makes it possible to establish and measure the detector-to-sample distance before the assembly is placed in the chamber. Because of easy access, the detector can be changed without the detector being touched. Another convenience is that the support rods on the sample mounting can be used as legs to support the cover when it is out of the chamber.

An opening in the wooden base allows an effective-geometry gamma detector to be placed against the bottom of the thin stainless steel chamber for beta-gamma coincidence measurements. In this application, an extension cable is used to mount the semiconductor detector close to the chamber base.

Since the vacuum pump and vent functions are combined in a single valve, the vacuum

pump does not have to be turned off while the samples are being changed. A quarter turn of the valve opens the chamber to vacuum while sealing off the vent passage.

The Model 807 is both functional and attractive, with its main housing made of stainless steel and mounted on a varnished wood base. The stainless steel valve comes with a Swagelok tube fitting which accepts a 1/4 inch OD (outside diameter) tube for the vacuum line. (NOTE: An ORTEC Portable Pump Station, Model ALPHA-PPS-115/230 or the ALPHA-MINI-PPS can be used with this chamber.)

The photograph also shows a measurement scale attached to a leg of the chamber cover. The scale measures the sample-to-detector distance.

diameter at base [vacuum shutoff valve projects 4.93 cm (1.94 in.) beyond base diameter]. Inside chamber dimensions are: 14.45 cm (5.69 in.) deep x 10.48 cm (4.125 in.) wide at the mouth of the chamber.

Ordering Information

To order, specify:

Model	Description
807	Vacuum Chamber

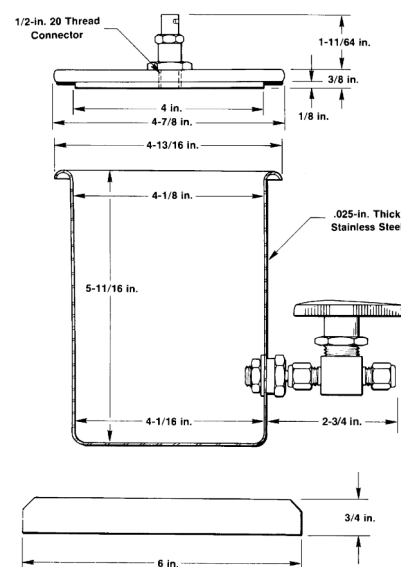

Model 807 Vacuum Chamber

Specifications

MATERIALS Aluminum, chrome-plated brass, stainless steel, and wood base.

DETECTOR-TO-SAMPLE DISTANCE
Variable up to ~12.7 cm (~5 in.).

CONNECTOR Female BNC outside, Microdot male inside.

WEIGHT

Net 1.1 kg (2.5 lb).

Shipping 2.0 kg (4.5 lb).

DIMENSIONS Overall dimensions are:
21.0 cm (8.25 in.) high x 15.24 cm (6.0 in.)

Specifications subject to change
092121