

- “Application-Matched” P-type HPGe Detectors, optimized for specific sample types, gamma energy ranges and measurement geometries.
- Best absolute efficiency for the given IEEE standard relative efficiency in your counting geometry.
- Stable thin front contact, no front dead layer growth even if stored warm (PROFILE GEM-S, -SP, and -C Series).
- Warranted crystal dimensions ensure measurement performance.
- Reproducible dimensions mean reproducible performance. . . no surprises.
- Full range of PopTop Cryostats and options.

The ORTEC PROFILE Series of P-type High Purity Germanium (HPGe) detectors offers specific crystal dimensions from which you can choose the best solution in YOUR application. Nominal relative efficiency specifications (warranted for C Series) are provided to help relate relative efficiency to terms of crystal dimensions. The efficiency is measured according to the IEEE standard.

S-Series PROFILE GEM Detectors

S-Series PROFILE detectors employ “over-square” (diameter > length) structures. This crystal geometry is often referred to as semi-planar structure. For a given relative (IEEE) efficiency, the S-Series represents the “best use” of germanium material producing the maximum absolute counting efficiency for on-endcap or “close geometry” extended samples, such as:

- Point sources on-endcap
- Filter paper samples on-endcap
- Samples presented in bottles and pots on-endcap
- Bio-assay applications (e.g., lung monitoring)
- Waste drum monitoring

S-Series PROFILE GEM detectors have a semi-planar crystal geometry and employ a proprietary ultra-thin, stable entrance window to improve low energy efficiency. The S-Series entrance window extends the useful energy range, while maintaining the excellent peak shape and resolution characteristics of the PROFILE series.

In addition, the over-square geometry helps improve (lowers) low-energy resolution by reduced crystal capacitance as compared to coaxial crystal geometry.

- Ultra-thin, stable entrance window.
- Excellent warranted performance.
- Excellent sensitivity down to 3 keV energy.
- No dead layer growth (change in efficiency) from the front of the crystal due to prolonged warm storage.

Figure 2 shows the extensive improvement in efficiency at lower energies for a PROFILE “S” detector when measuring a point source. Calculated (color) curves show absolute efficiency versus energy for a point source positioned 25 cm from the detector endcap. The S8530 (light green) S-Series detector’s absolute efficiency is significantly higher between 10 keV and 600 keV when compared to the same 50% relative efficiency coaxial P- and N-type detectors. At 59 keV, the 85 mm crystal diameter S-Series detector is nearly 6X more efficient than a P-type coaxial detector (GEM50) (red) and almost 2X more efficient than a coaxial N-type (GMX50) (blue) low-energy detector due to its greater front surface area. As expected, curves converge at 1332 keV, where relative efficiency is measured. The S9430 (green) and S10530 (dark green) unique detectors, with 94 mm and 105 mm crystal diameter respectively, further improve absolute efficiencies below 1 MeV due to a larger surface area.

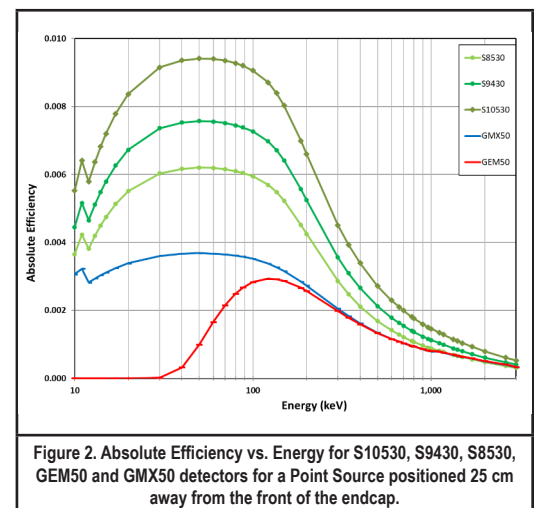
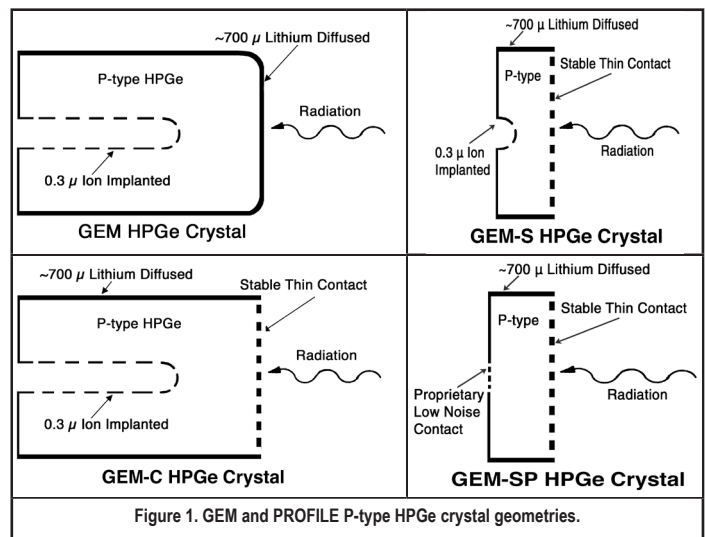

PROFILE HPGe Photon Detector Product Configuration Guide

Figure 3 reinforces the marked improvement in efficiency for the PROFILE “S” detectors when measuring a filter paper on-endcap source. Calculated (color) curves show absolute efficiency versus energy for a 100 mm diameter filter paper source positioned on the detector endcap. The S8530 (light green) has significantly higher absolute efficiency at all energies below 1 MeV down to 10 keV. Due to a larger diameter crystal, at 122 keV, the S-Series detector is 1.9X more efficient than a P-type coaxial (red) and nearly 1.4X more efficient than an N-type (blue) low-energy detector. The S9430 (green) and S10530 (dark green) unique detectors, with 94 mm and 105 mm crystal diameter respectively, further improve absolute efficiencies below 1 MeV due to a larger surface area.

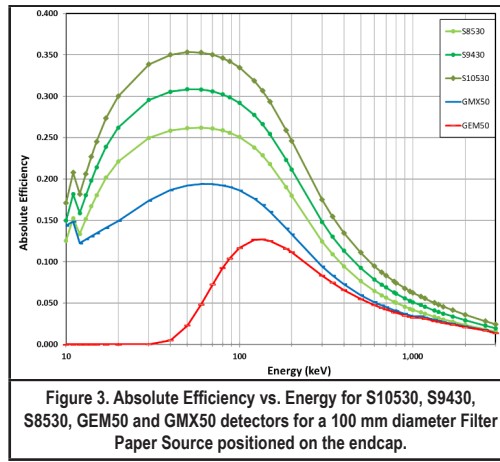

Figure 3. Absolute Efficiency vs. Energy for S10530, S9430, S8530, GEM50 and GMX50 detectors for a 100 mm diameter Filter Paper Source positioned on the endcap.

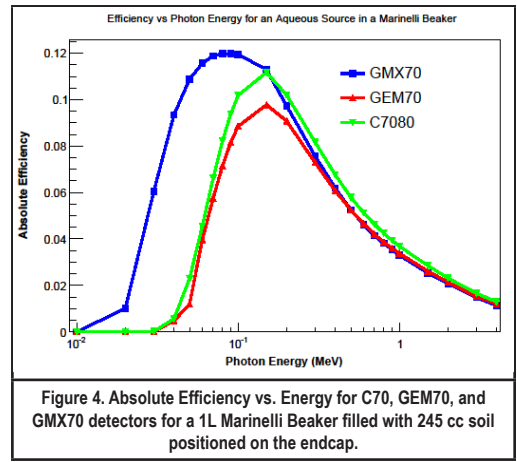

Figure 4. Absolute Efficiency vs. Energy for C70, GEM70, and GMX70 detectors for a 1L Marinelli Beaker filled with 245 cc soil positioned on the endcap.

Figure 4 shows marginal efficiency advantage for the PROFILE “C” detectors when measuring a 1L Marinelli Beaker with 245 cc soil on the endcap source for energies above 200 keV. This advantage of PROFILE C detectors is due to maximizing the crystal diameter within the endcap. The N-type GMX70 (blue) detector has better efficiency than the C70 (light green) and the P-type GEM70 (red) as expected due to the thinner contact on the sides of the detector. However, a C70 offers better resolution performance than an N-type detector. The decision to offer a GMX vs. a PROFILE C detector for low energies with a Marinelli Beaker source geometry should be based on what is more valuable for a given application — resolution or efficiency.

Figures 4, 5 and 6 highlight the robust peak shape of PROFILE “S” and “C” detectors measuring ⁵⁵Fe and ¹⁰⁹Cd spectra respectively. The low energy peak at 5.9 keV on the left, and 22 and 88 keV peaks on the right are well defined.

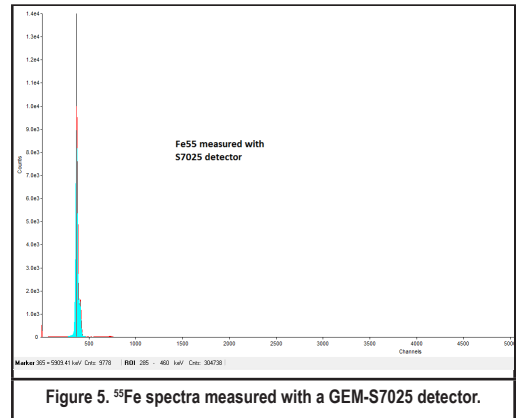

Figure 5. ⁵⁵Fe spectra measured with a GEM-S7025 detector.

SP-Series PROFILE GEM Detectors

- All the advantages of the S-Series PROFILE detectors with a proprietary low noise back contact.
- Premium warranted resolution performance.
- SP-Series detectors are designed for use in low count-rate applications.

Semi-planar SP-Series PROFILE GEM detectors use a low-noise back contact in addition to the proprietary ultra-thin, stable entrance window introduced with the S- and C-Series. As in the S-Series, the front contact delivers excellent transmission at low energies. Thermal cycling or warm storage of the detector will not degrade the transmission efficiency of the front contact.

Unique to the SP-Series detector is the proprietary back contact that dramatically improves detector resolution at low energies.

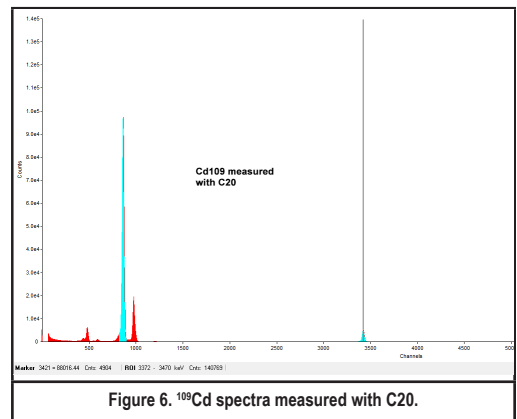

Figure 6. ¹⁰⁹Cd spectra measured with C20.

PROFILE HPGe Photon Detector Product Configuration Guide

The resolution improvement above the S-Series is illustrated in Figure 7 where two peaks from an ^{55}Fe point source positioned 25 cm away from the front of the endcap are overlaid. The full width half max (FWHM) resolution at 5.9 keV energy for the SP8530 is 25% lower as compared to the same diameter and thickness S8530 detector. The 5.9 and 6.5 keV peaks measured with the SP8530 detector (shown in blue) are clearly separated, while the S8530 (shown in red) has more peak overlap.

Figure 8 shows 10% improvement in resolution for the PROFILE SP8530 over the S8530 for the 122 keV peak from a ^{57}Co point source.

The improvement is even more dramatic when comparing with a conventional P-type detector. Figure 9 displays spectra for a mixed gamma source for a PROFILE SP8530 and a GEM50 detector. Both the SP8530 and GEM50 detectors have relative efficiency specifications of 50% and similar resolution at 1332 MeV. The resolution of the SP8530 is 45% better at 60 keV and 30% better at 122 keV. This improvement in resolution translates into a substantial reduction in Minimum Detectable Activity (MDA) at those energies.

General Guidelines for Choosing an S- or SP-Series PROFILE GEM Detector

For a close or on-endcap sample, the detector diameter should exceed the sample diameter by 20% or more. Beyond 30% the gain in efficiency is small. In addition, if the detector diameter exceeds the sample diameter by 20% or more, errors due to irreproducibility of the sample position will be minimal.

If budget constraints must be considered, first select the largest diameter in comparison with the optimum diameter. Selection of a deeper detector will further increase the absolute efficiency, specifically at higher energies. For samples counted in geometries similar to those listed above, choose an S-Series PROFILE detector with a diameter 20% (or more) larger than the sample to ensure the highest absolute efficiency at lower energies between 3 to 50 keV. If the application or situation includes prolonged storage of the detector in an ambient environment, selection of the S-Series PROFILE detector will maintain excellent performance, with no degradation in the low-energy range. Over-square detectors can often achieve better lowenergy resolution than longer, smaller diameter detectors of the same relative efficiency.

Choose an SP-Series PROFILE detector for premium resolution performance at low and medium energies. The premium resolution advantage is vital for applications using multi-nuclide (multi-peak) identification. Better resolution enhances the performance of peak locate algorithms, which leads to fewer false positives and double peaks. Better resolution performance of SP-Series PROFILE detectors translates into an improved Peak to Background ratio, which in turn implies lower MDA and shorter counting times.

Keep in mind, GEM-SP detectors are designed for use in low count-rate applications.

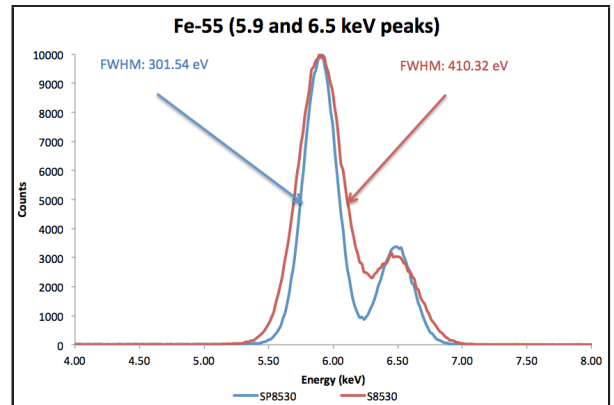

Figure 7. Resolution for SP8530 (blue) and S8530 (red) detectors measured with a ^{55}Fe Point Source positioned 25 cm from the front of the endcap.

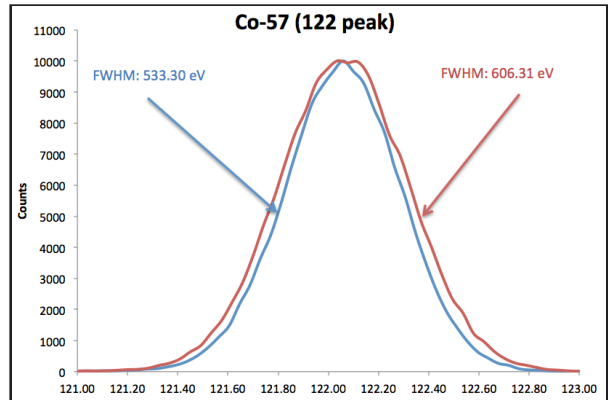

Figure 8. Resolution of SP8530 (blue) and S8530 (red) detectors measured with a ^{57}Co Point Source positioned 25 cm from the front of the endcap.

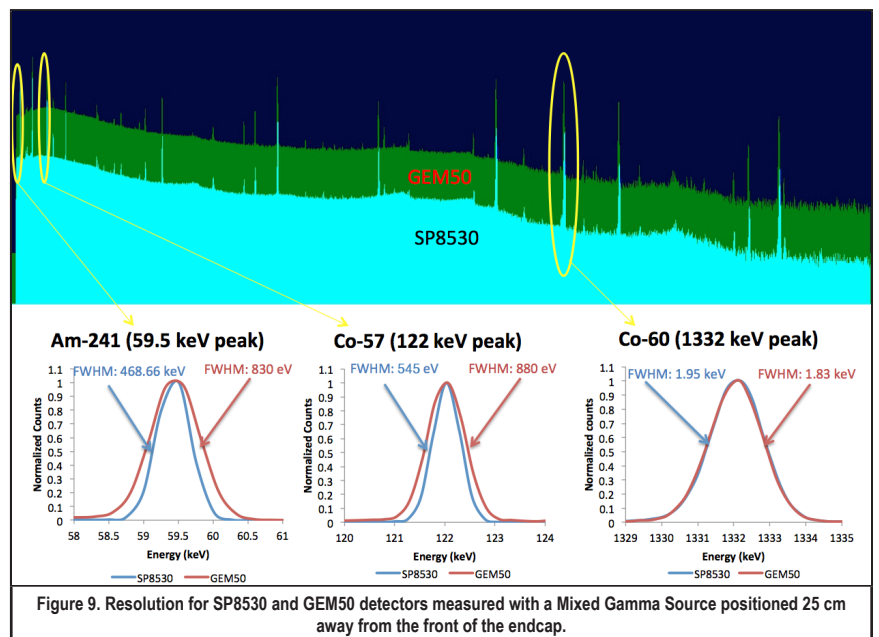

Figure 9. Resolution for SP8530 and GEM50 detectors measured with a Mixed Gamma Source positioned 25 cm away from the front of the endcap.

PROFILE HPGe Photon Detector

Product Configuration Guide

M-Series PROFILE GEM Detectors

The M-Series detectors are designed for use with Marinelli beakers to provide an optimum solution and efficiency. M-Series detectors provide the same resolution and better absolute efficiency (below 50 keV) than GEM series detectors, and better resolution but lower absolute efficiency (below 50 keV) than GMX series detectors. These are made where the endcap diameter is “filled with the crystal” and the length is slightly longer than the diameter. The overall absolute efficiency for a Marinelli beaker is maximized. This is the most common beaker where the well diameter is equal to its length. Additionally, M-Series for a given relative (IEEE) efficiency, represents the optimum “use” of germanium material, generating the maximum absolute counting efficiency for on-endcap or “close geometry” extended samples with a higher energy range requirement than S- or SP-Series, such as:

- Point sources on-endcap
- Filter paper samples on-endcap
- Samples presented in bottles and pots on-endcap
- Waste drum monitoring

C-Series PROFILE GEM Detectors

The C-Series detectors provide detectors combined with an ultra-thin, stable entrance window. This extends the lowest usable energy down to 5 keV while maintaining the efficiency at higher energies. Nuclides such as ²⁴¹Am and ²¹⁰Pb may be measured while providing excellent efficiency for higher energy emitters; all in a single detector. The largest of these detectors provides the maximum efficiency available in a single detector for energies greater than 3 MeV.

General Guidelines for Choosing an M-Series or C-Series PROFILE GEM Detector

Choosing the optimum M- or C-Series detector for use with a specific Marinelli beaker could not be easier: simply choose the detector with the tightest fit inside the Marinelli beaker well!

An S- or SP-Series detector may be used in a Marinelli geometry, it will have better resolution performance, but will have lower efficiency than an M- or C-Series detector of the same diameter. Correspondingly, an M- or C-Series detector may be used as a substitute for an S- or SP-Series detector in an on-endcap geometry. For the same diameter, the M- or C-Series will give slightly higher efficiency (improvement increasing with increasing energy).

Overall Guidelines on the Choice of High Purity Germanium (HPGe) Detector						
Source Energy (keV)	Marinelli Beaker		Near or Far Point Source		Large Surface Area	
	Best Efficiency	Best Resolution	Best Efficiency	Best Resolution	Best Efficiency	Best Resolution
3 to 3000	GMX	PROFILE C	PROFILE S or SP	PROFILE S or SP	PROFILE S or SP	PROFILE S or SP
3 to 10000	GMX	PROFILE C	PROFILE C	PROFILE C	PROFILE C	PROFILE S or SP
20 to 3000	GMX	PROFILE M	PROFILE C	PROFILE C	PROFILE C	PROFILE C
50 to 5000	GEM	GEM	GEM	GEM	GEM	PROFILE C
20 to above 10000	GMX70 or larger	PROFILE C70 or larger	PROFILE C70 or larger	PROFILE C70 or larger	PROFILE C70 or larger	PROFILE C70 or larger
above 5000	GMX70 or larger	GEM70 or larger	GEM70 or larger	GEM70 or larger	GEM70 or larger	GEM70 or larger
Neutron Damage	GMX	GMX	GMX	GMX	GMX	GMX
High Count Rate	small GEM or GMX	small GEM or GMX	small GEM	small PROFILE S	small PROFILE S	small PROFILE S

PROFILE HPGe Photon Detector Product Configuration Guide

The Following Data are Provided with each PROFILE Series Detector

- Measured energy resolution for 1.33 MeV photons from ^{60}Co .
- Measured crystal dimensions.
- Measured relative efficiency.
- Measured Peak-to-Compton ratio for ^{60}Co 1.33 MeV peak.
- Measured peak shape ratio of the full-width tenth-maximum to the full-width half-maximum for ^{60}Co 1.33 MeV peak.
- Measured energy resolution for 122 keV photons from ^{57}Co for the GEM-M, GEM-S, GEM-SP and GEM-C.
- Measured energy resolution at 5.9 keV for the GEM-S, GEM-SP and GEM-C detectors equipped with carbon fiber windows.

Configuration Guidelines

PopTop or Streamline (non-PopTop) Configuration

The essence of a PopTop detector system is that the HPGe detector element, preamplifier, and high voltage filter are housed in a detector “capsule” which is then attached to an appropriate cryostat (Figure 10.)

In Streamline systems, the detector capsule is NOT demountable. Detector capsule and cryostat share the same vacuum. In configuration terms, this requires a cryostat or cryostat/dewar selection with the cryostat having a matching diameter to the capsule endcap or an integrated cryocooling system (ICS). A cryostat or ICS must always be ordered with a Streamline capsule, because they are integral.

The actual PopTop capsule has its own vacuum. It can be mounted on any of the available cryostats, cryostat/dewar combinations, or the ICS-P4 mechanical cooling system.

Certain cryostat configurations are available only as PopTop and others are available only as Streamline.

Steps to Configure Your ORTEC HPGe Detector

1) Configure the Detector Model

- Capsule type (PopTop or Streamline)
- Ge Crystal dimensions and specifications
- Endcap and window
- Mount
- Preamplifier
- High Voltage Filter
- Cable Package
- Integrated Cryocooling System (ICS)

Options are available for the detector model that can change specific materials used in the construction of the detector endcap, cup, and mount. Preamplifier options are also available.

2) Configure the Cryostat/Dewar or ICS Model

- Vertical Dipstick style (separate Dewar or Mobius Recycler)
- Horizontal Dipstick style (separate Dewar or Mobius Recycler)
- Portable with all-position or multi-position cryostat/dewar models
- Downlooking designed to be oriented with the detector pointing down
- Sidelooking designed to be oriented with the detector horizontal at the bottom of the dewar
- “J” configurations designed with the detector attached near the bottom of the dewar and a right angle bend in the cryostat orienting the detector to look up.

A cryostat and dewar or other cooling device are required for operation.

If a PopTop detector has been selected, you can choose a PopTop style cryostat, cryostat/dewar combination or the ICS-P4 mechanical cooling systems.

If a Streamline detector has been selected, you must choose a cryostat or cryostat/dewar model for the detector to be mounted on and vacuum sealed or an ICS. The cryostat, cryostat/dewar combination or ICS diameter must match the endcap diameter of the selected detector.

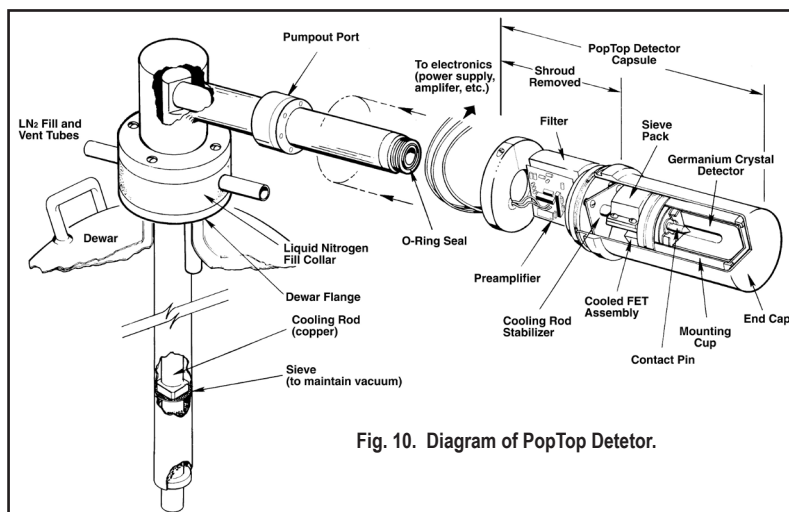

PROFILE HPGe Photon Detector Product Configuration Guide

Detector Options

Integrated Cryocooling System Option (-ICS-E, ICS-HJ)

The Integrated Cryocooling System (ICS) cryostat is sealed with a cryocooler and is immune to thermal short cycling. Unlike the typical three day loss of use of the detector with a standard type cryostat, the ICS can be re-cooled immediately, minimizing any time lost for temporary warm up.

Integrated Cryocooling Low-Background System (-ICS-LB-HJ)

Low-background detector, high purity aluminum endcap, high purity aluminum window, high purity aluminum internal cup, and low-background Cu mount for the ICS Integrated Cryocooling System. The lower background material allows for lower Minimum Detectable Activity (MDA) for a specific counting time, which provides another step in increasing sample throughput in low-background applications.

Ultra-High Count-Rate Preamplifier Option (-PL)

The Ultra-High Count-Rate Preamplifier (transistor-reset preamplifier), which can handle input count rates up to 1,000,000 counts/s at 1 MeV, offers the added benefit of having no feedback resistor.

SMART-1 Option (-SMP)

The SMART-1 option monitors and reports on vital system functions, and can save authentication codes and report the code at a later time. It has the high voltage included, so none of the instruments require an external high-voltage power supply.

The SMART-1 is housed in a rugged ABS molded plastic enclosure and is permanently attached to the detector endcap via a molded-strain-relieved sealed cable. This eliminates the possibility that the detector will suffer severe damage from moisture leaking into high-voltage connectors. The SMART-1 can be positioned in any convenient place and does not interfere with shielding or other mounting hardware.

Remote Preamplifier Option (-HJ)

This option allows all the preamplifier and high voltage connections to be outside a shield and removes the preamplifier and high voltage filter from the "line-of-sight" to the Ge crystal. For low background applications, this option eliminates any possible preamplifier or high voltage filter components that may add to the background inside a shield.

Low-Background Carbon Fiber Endcap Options (-RB, -LB-C, and -XLB-C)

Carbon Fiber is as strong as Al, Mg, and Cu, creates less background and does not corrode.

This lower background material allows for lower Minimum Detectable Activity (MDA) for a specific counting time, which provides another step in increasing sample throughput in low-background counting applications. The lower Z of Carbon Fiber provides a low-energy window without the additional background found in most alloys. See Table 1 for transmission characteristics of carbon fiber windows.

Carbon Fiber, unlike Beryllium, is non-toxic and can be cleaned with most laboratory solvents such as methanol, trichloroethylene, and acetone. Soap and water may also be used. Abrasive cleaners should not be used.



Fig. 11. ICS Integrated Cryocooling Systems

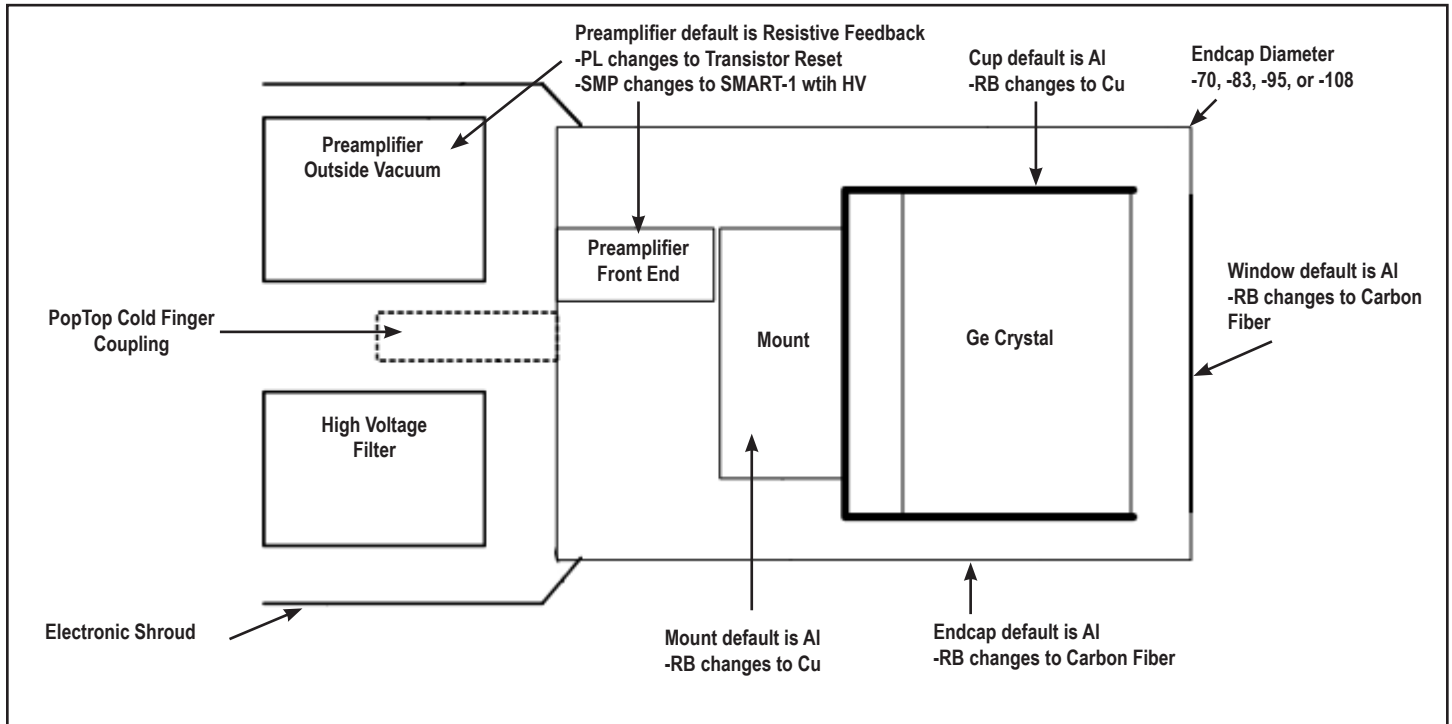

Fig. 12. SMART-1 Detector Interface Module.

Energy (keV)	Aluminum Window % Transmission	Carbon Fiber Window % Transmission
3	0	0.29
5	0	23
10	0.09	82
20	40	97
30	74	99
50	91	100
80	95	100
100	96	100
400	97	100
1000	98	100

PROFILE HPGe Photon Detector Product Configuration Guide

PopTop GEM-M Detector Capsule



PopTop GEM-S, GEM-SP, and GEM-C Detector Capsule

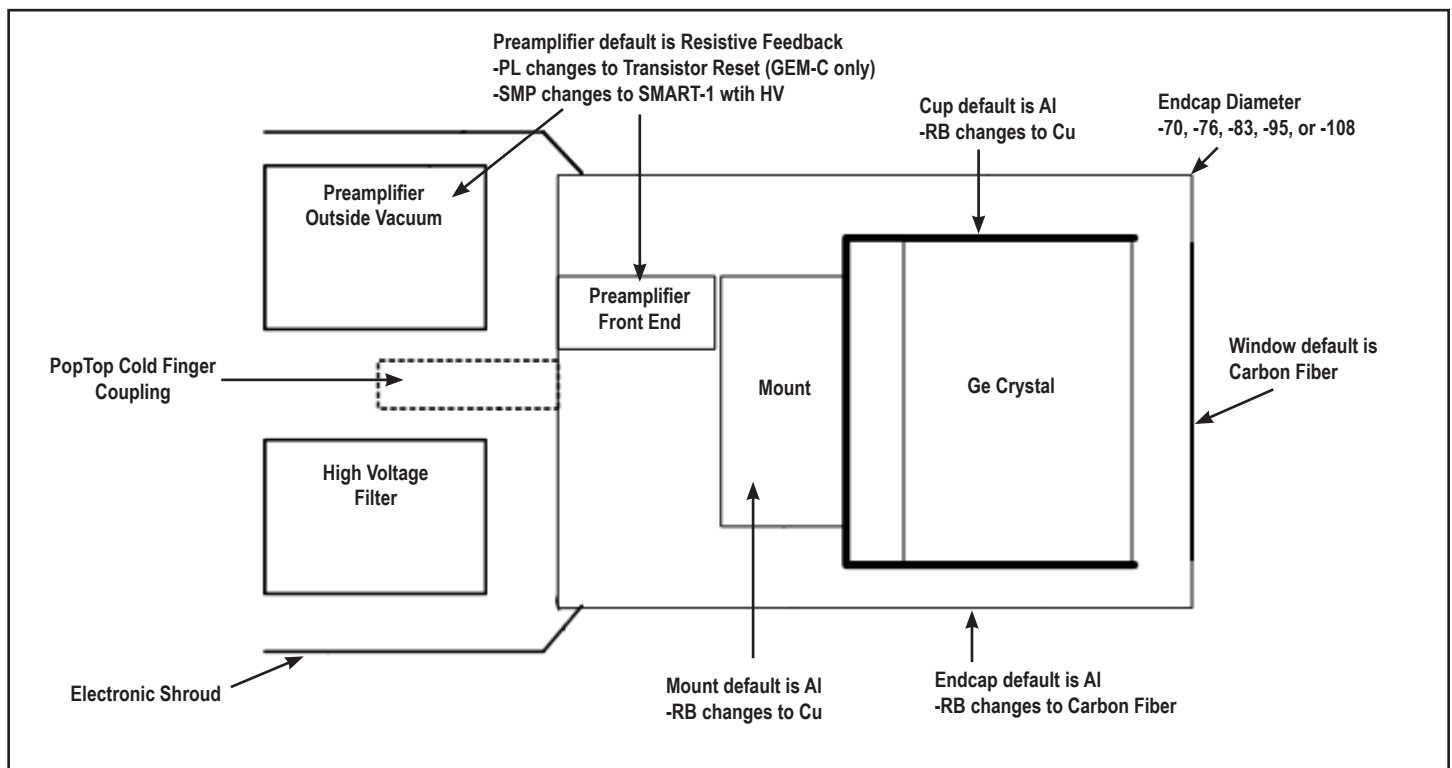

PROFILE HPGe Photon Detector Product Configuration Guide

Streamline GEM-M Detector Capsule

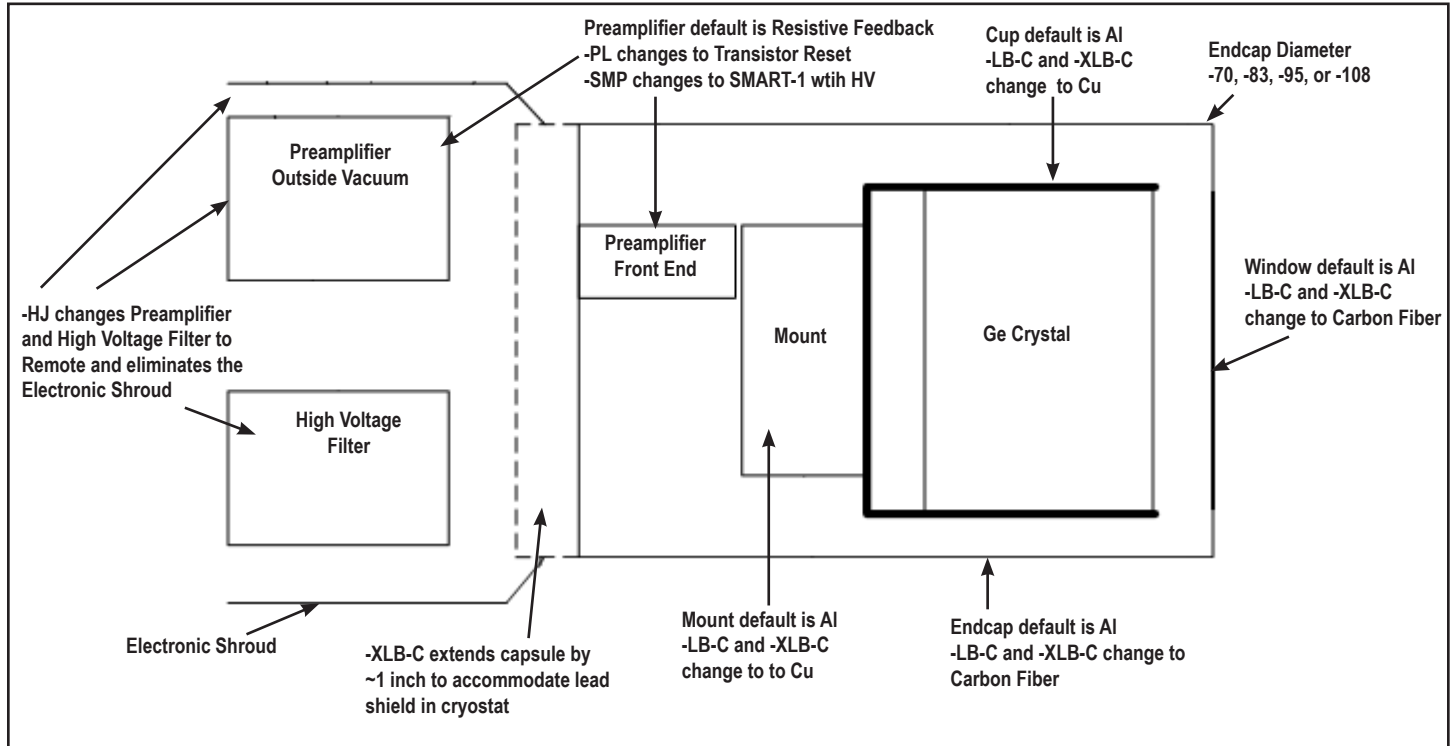

Streamline GEM-S, GEM-SP, and GEM-C Detector Capsule

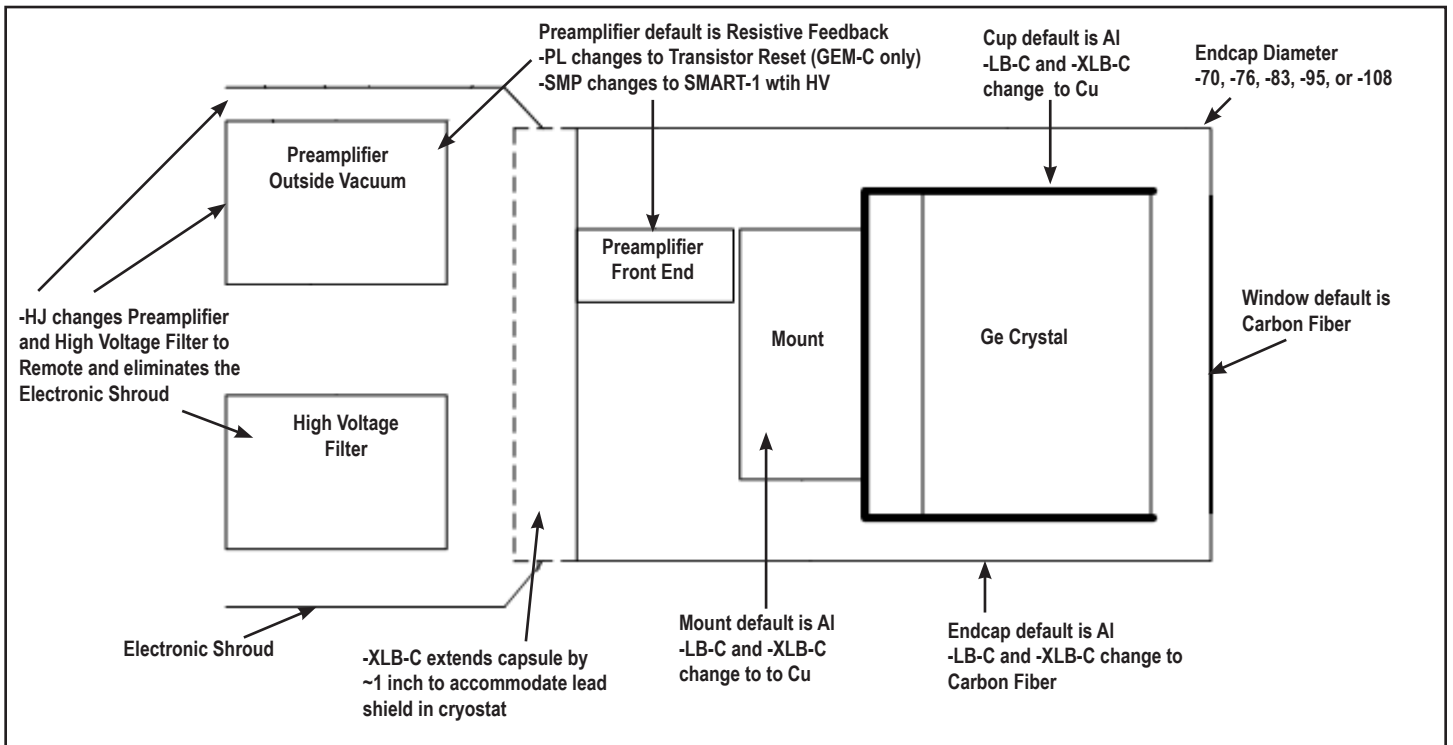

PROFILE HPGe Photon Detector Product Configuration Guide

Streamline Detector Capsule for Integrated Cryocooling System (ICS-E)

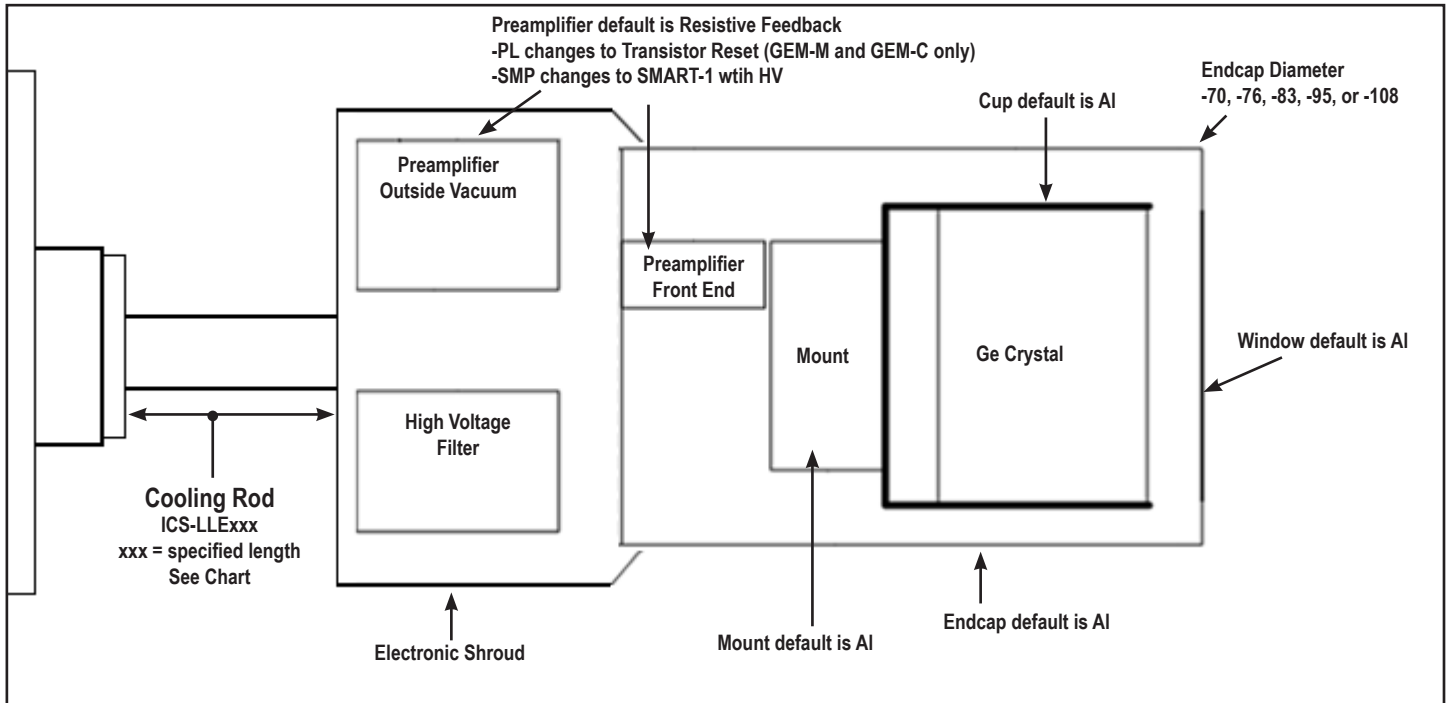

Streamline Detector Capsule for Integrated Cryocooling System with Remote Pre-amplifier (ICS-HJ)

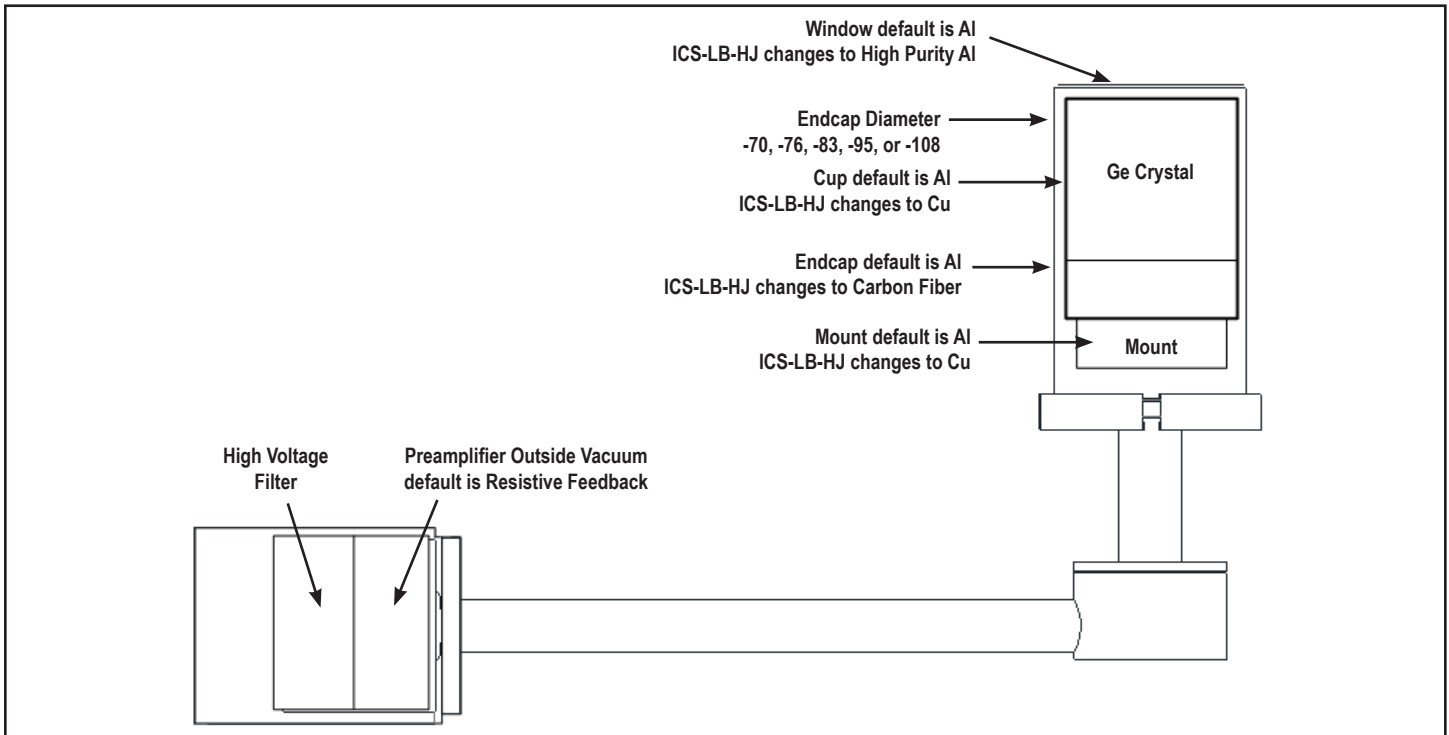

PROFILE HPGe Photon Detector Product Configuration Guide

Streamline Cryostat and Cryostat/Dewar Assemblies

Streamline systems (detector capsule and cryostat) share the same vacuum, requiring a cryostat or cryostat/dewar selection with the cryostat having a matching diameter to the capsule endcap.

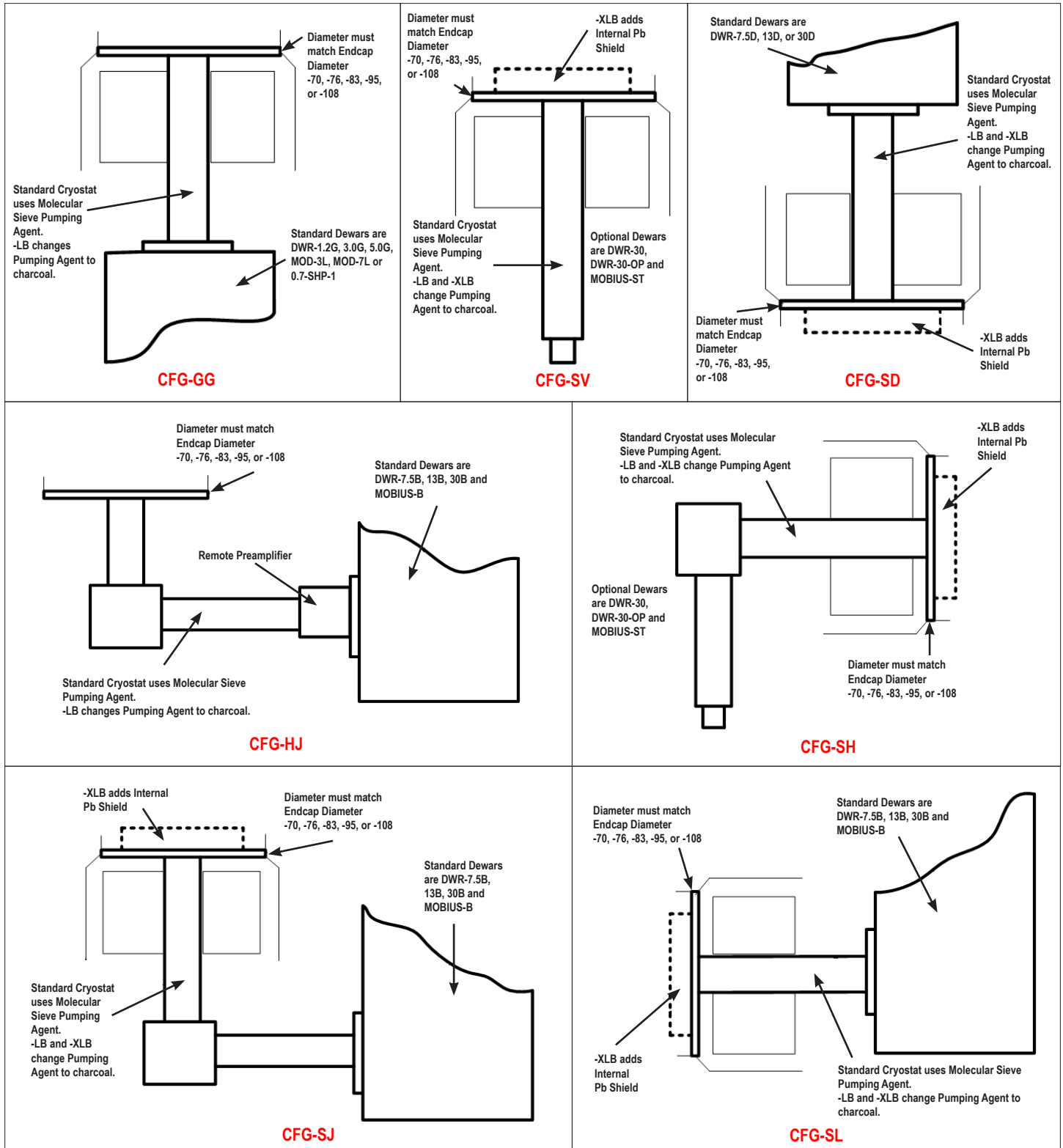

PROFILE HPGe Photon Detector Product Configuration Guide

PopTop and Streamline Dimensional Data

Streamline systems (detector capsule and cryostat or ICS) share the same vacuum. A cryostat or ICS must be ordered with a Streamline capsule. The cryostat or cryostat/dewar selection must have a matching diameter to the capsule endcap.

The PopTop capsule features an internal vacuum arrangement. It can be mounted on any of the available PopTop cryostats, cryostat/dewar combinations, or ICS-P4 mechanical cooling systems.

The cryostat and dewar drawings that follow are to be used in conjunction with the accompanying tables of dimensions.

**Note: Cryostat/Dewar drawings are NOT to scale, see tables that follow for complete dimensions.
Dimensions are for reference only and subject to change, if dimensional constraints are critical, contact the factory.**

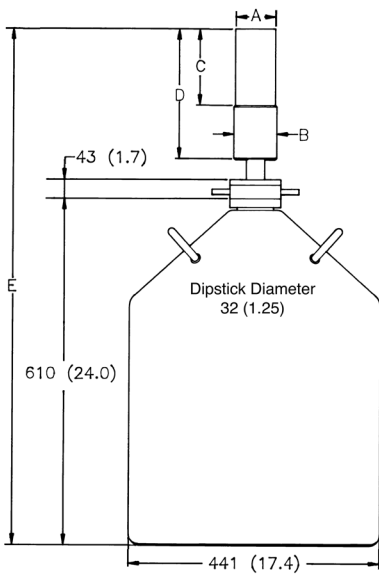

CFG-SV, DWR-30

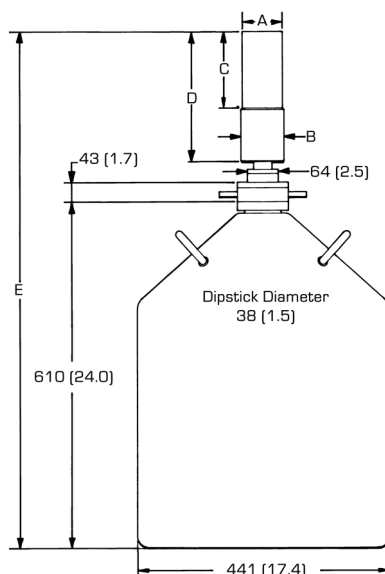

CFG-PV4, DWR-30

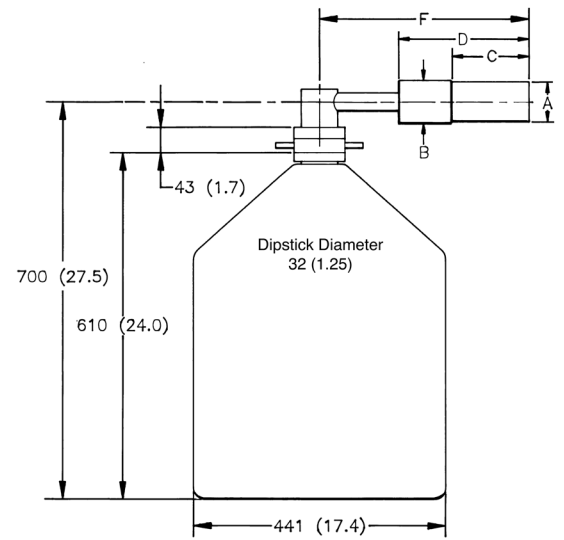

CFG-SH, DWR-30

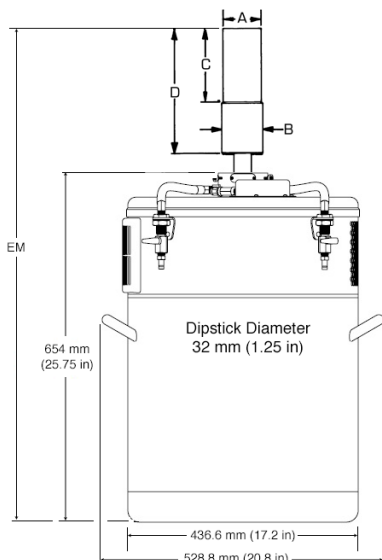

CFG-SV, MOBIUS-ST

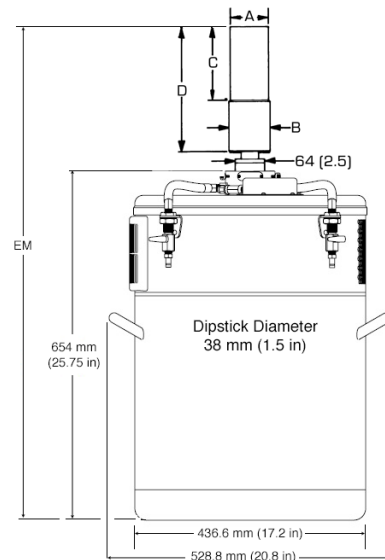

CFG-PV4, MOBIUS-PT

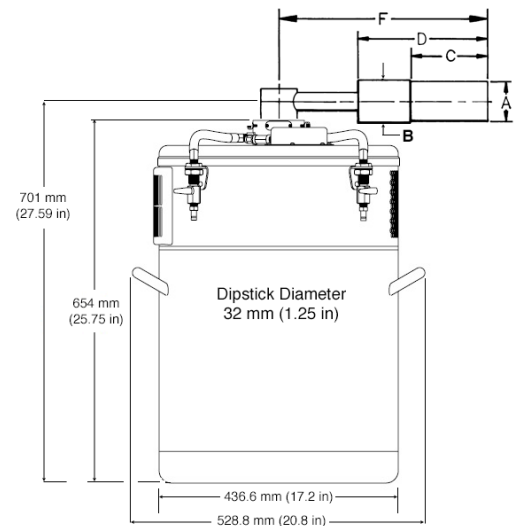

CFG-SH, MOBIUS-ST

PROFILE HPGe Photon Detector Product Configuration Guide

**Note: Cryostat/Dewar drawings are NOT to scale, see tables that follow for complete dimensions.
Dimensions are for reference only and subject to change, if dimensional constraints are critical, contact the factory.**

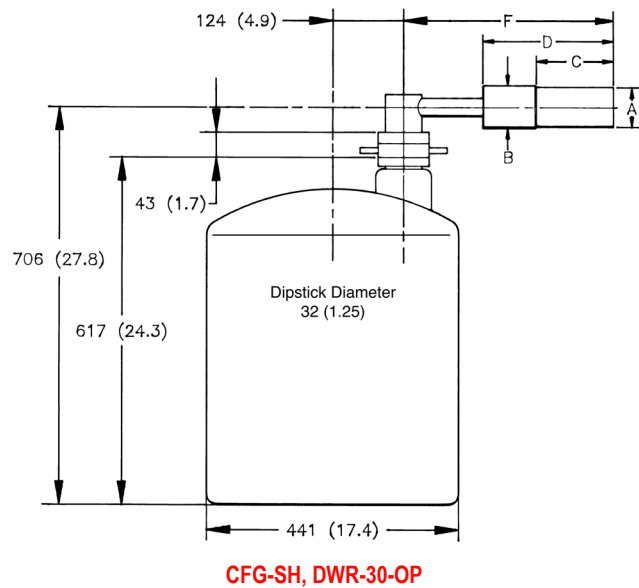
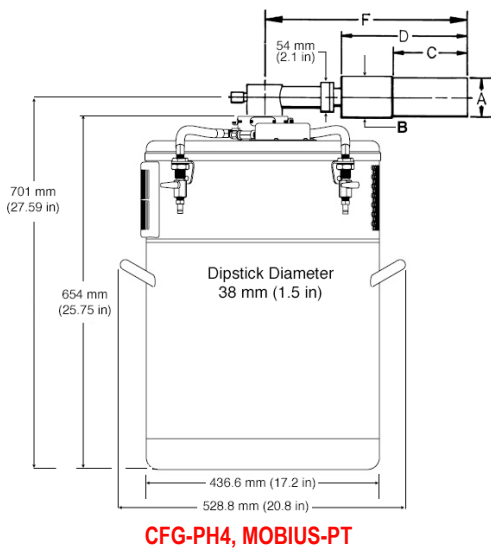
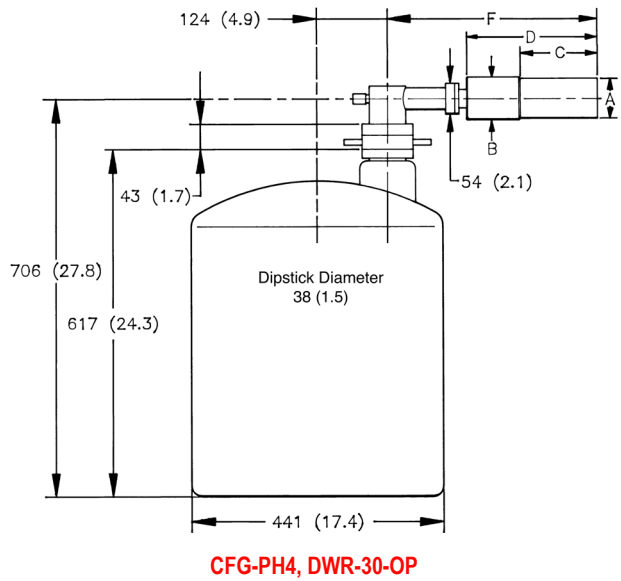
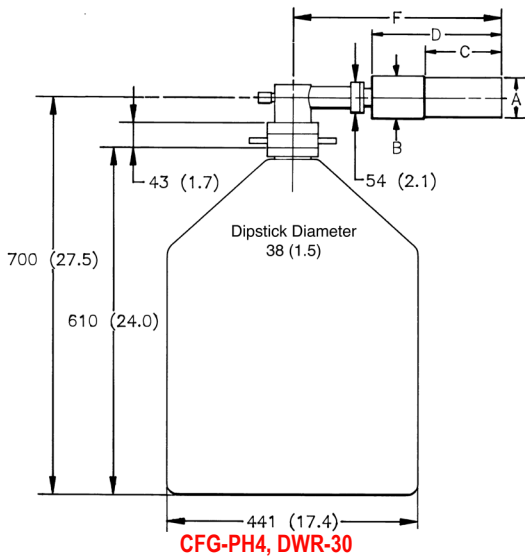

PROFILE HPGe Photon Detector Product Configuration Guide

**Note: Cryostat/Dewar drawings are NOT to scale, see tables that follow for complete dimensions.
Dimensions are for reference only and subject to change, if dimensional constraints are critical, contact the factory.**

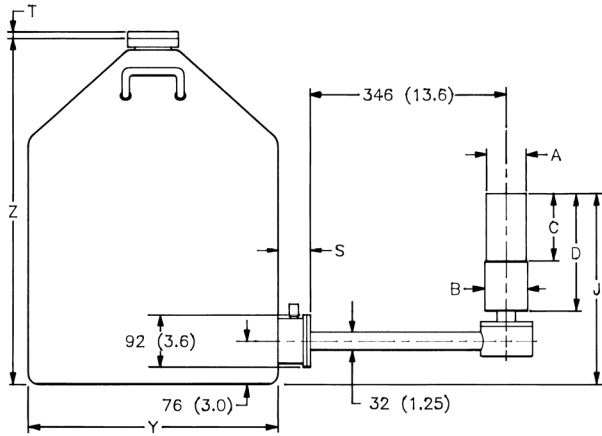

CFG-SJ, DWR-30B (or -13B or -7.5B)

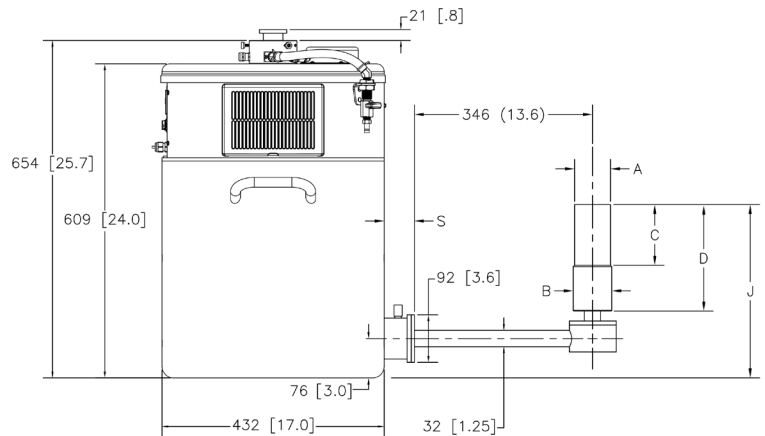

CFG-SJ, MOBIUS-B

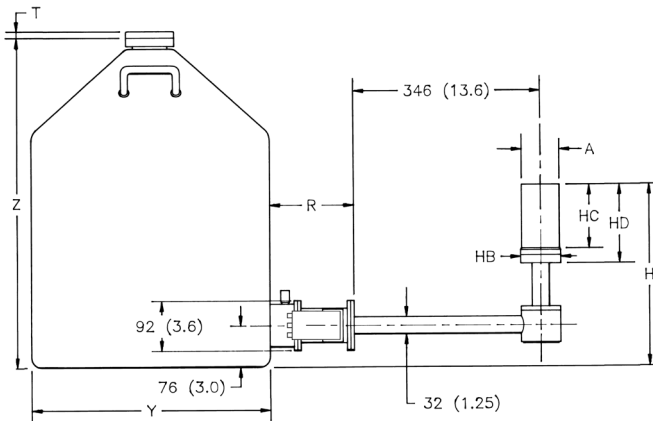

CFG-HJ, DWR-30B (or -13B or -7.5B)

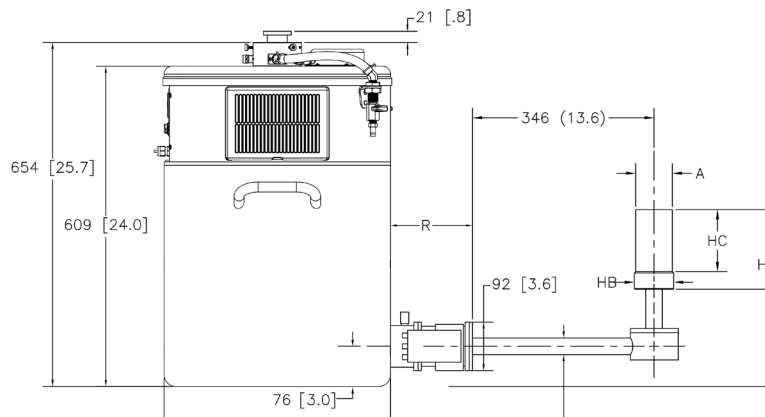

CFG-HJ, MOBIUS-B

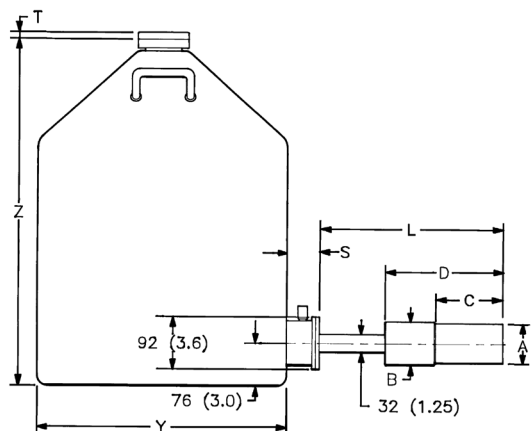

**CFG-PS4-30 (or -13 or -7.5) or
CFG-SL, DWR-30B (or -13B or -7.5B)**

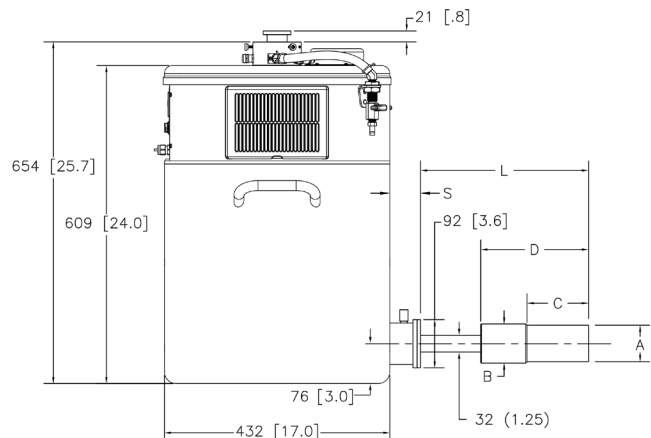

CFG-PS4-MOBIUS-B or CFG-SL, MOBIUS-B

PROFILE HPGe Photon Detector Product Configuration Guide

**Note: Cryostat/Dewar drawings are NOT to scale, see tables that follow for complete dimensions.
Dimensions are for reference only and subject to change, if dimensional constraints are critical, contact the factory.**

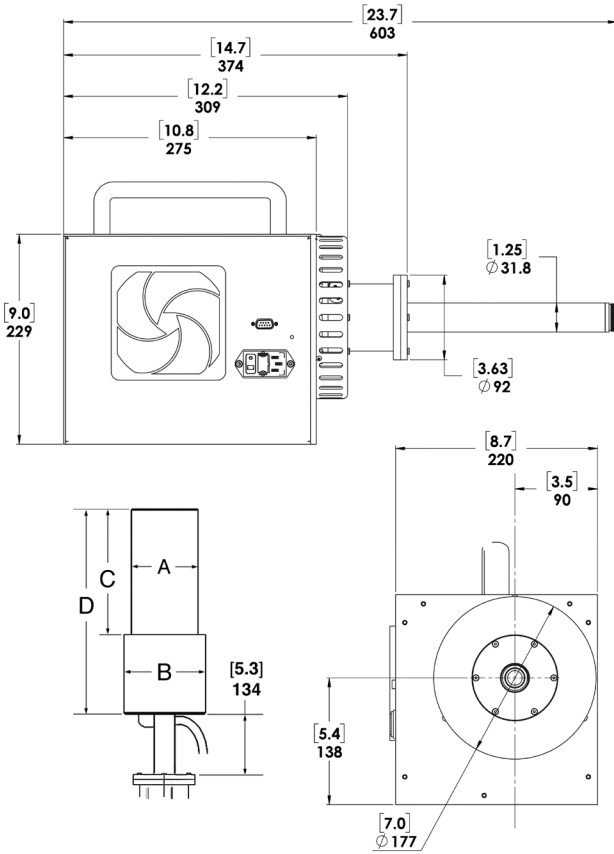

CFG-ICS-P4

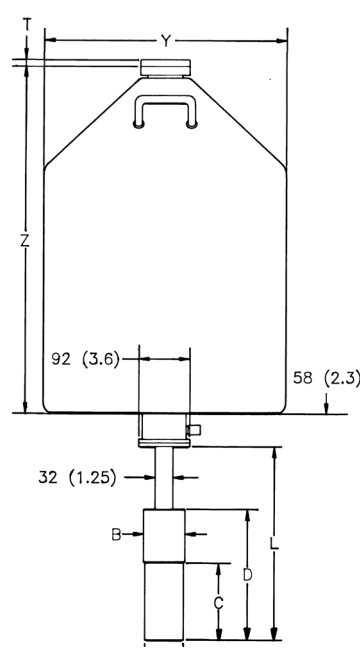

**CFG-PD4-30 (or -13 or -7.5) or
CFG-SD, DWR-30D (or -13D or -7.5D)**

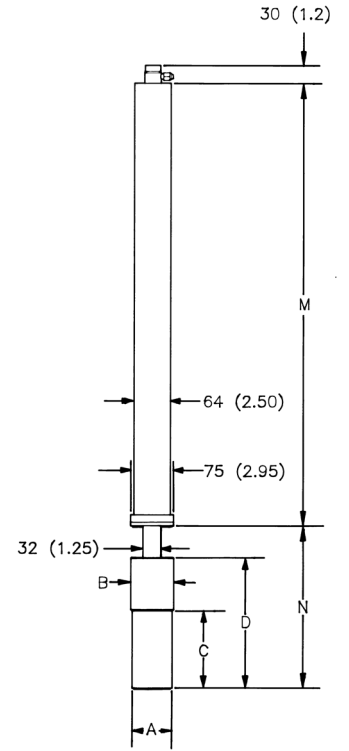

**CFG-PSHP4 or
CFG-GG, DWR-0.7-SHP-1**

PROFILE HPGe Photon Detector Product Configuration Guide

PopTop PROFILE Series Detector Dimensions

- Dimensions are for reference only and subject to change.
- If dimensional constraints are critical, contact the factory.

Endcap Model (dia. mm)			-70	-76	-83	-95	-108
Dim.	Unit	Tol.					
A	mm (in)	0.3 (0.01)	70 (2.75)	76 (3.0)	83 (3.25)	95 (3.75)	108 (4.25)
B	mm (in)	0.3 (0.01)	75 (2.95)	88 (3.45)	88 (3.45)	100 (3.95)	113 (4.45)
C	mm (in)	5 (0.2)	134 (5.3)	165 (6.4)	168 (6.6)	193 (7.6)	207 (8.2)
D	mm (in)	8 (0.3)	250 (9.8)	282 (11.2)	282 (11.2)	309 (12.2)	323 (12.7)
E	mm (in)	18 (0.7)	947 (37.3)	982 (38.6)	982 (38.6)	1007 (39.7)	1019 (40.1)
EM	mm (in)	19 (0.75)	948 (37.3)	983 (38.7)	983 (38.7)	1008 (39.7)	1020 (40.1)
F	mm (in)	10 (0.4)	396 (15.6)	429 (16.9)	429 (16.9)	455 (17.9)	469 (18.5)
L	mm (in)	10 (0.4)	338 (13.3)	371 (14.6)	371 (14.6)	396 (15.6)	412 (16.2)
M	mm (in)	8 (0.3)	790 (31.1)	X X	X X	X X	X X
N	mm (in)	10 (0.4)	278 (10.9)	312 (12.3)	312 (12.3)	338 (13.3)	348 (13.7)

PROFILE HPGe Photon Detector

Product Configuration Guide

Streamline PROFILE S and SP Series Detector Dimensions

- Dimensions are for reference only and subject to change.
- If dimensional constraints are critical, contact the factory.

			Standard or LB			XLB		
Endcap Model (dia. mm)			-70	-83	-108	-70	-83	-108
Dim.	Unit	Tol.						
A	mm (in)	0.3 (0.01)	70 (2.75)	83 (3.25)	108 (4.25)	70 (2.75)	83 (3.25)	108 (4.25)
B	mm (in)	0.3 (0.01)	75 (2.95)	88 (3.45)	113 (4.45)	75 (2.95)	88 (3.45)	113 (4.45)
C	mm (in)	5 (0.2)	89 (3.5)	84 (3.3)	96 (3.8)	115 (4.5)	109 (4.3)	121 (4.8)
D	mm (in)	8 (0.3)	202 (7.9)	208 (8.2)	220 (8.7)	227 (8.9)	234 (9.2)	246 (9.7)
E	mm (in)	18 (0.7)	875 (34.4)	881 (34.7)	898 (35.4)	900 (35.4)	907 (35.7)	923 (36.4)
EM	mm (in)	19 (0.75)	876 (34.5)	882 (34.7)	899 (35.4)	901 (35.5)	908 (35.7)	924 (36.4)
F	mm (in)	10 (0.4)	324 (12.8)	330 (13)	343 (13.5)	349 (13.8)	356 (14)	368 (14.5)
H	mm (in)	18 (0.7)	307 (12.1)	313 (12.3)	326 (12.9)	X X	X X	X X
HB	mm (in)	0.3 (0.1)	73 (2.9)	85 (3.4)	111 (4.4)	X X	X X	X X
HC	mm (in)	5 (0.2)	91 (3.6)	85 (3.3)	97 (3.8)	X X	X X	X X
HD	mm (in)	10 (0.4)	117 (4.9)	124 (4.9)	137 (5.4)	X X	X X	X X
J	mm (in)	10 (0.4)	336 (13.2)	342 (13.5)	355 (14)	361 (14.2)	367 (14.5)	380 (15)
L	mm (in)	10 (0.4)	293 (11.5)	300 (11.8)	312 (12.3)	319 (12.6)	325 (12.8)	338 (13.3)
N	mm (in)	10 (0.4)	234 (9.2)	240 (9.5)	253 (10)	259 (10.2)	266 (10.5)	279 (11)

PROFILE HPGe Photon Detector Product Configuration Guide

Streamline PROFILE M and C Series Detector Dimensions

- Dimensions are for reference only and subject to change.
- If dimensional constraints are critical, contact the factory.

Endcap Model (dia. mm)			Standard or LB					XLB				
Dim.	Unit	Tol.	-70	-76	-83	-95	-108	-70	-76	-83	-95	-108
A	mm (in)	0.3 (0.01)	70 (2.75)	76 (3.0)	83 (3.25)	95 (3.75)	108 (4.25)	70 (2.75)	76 (3.0)	83 (3.25)	95 (3.75)	108 (4.25)
B	mm (in)	0.3 (0.01)	75 (2.95)	88 (3.45)	88 (3.45)	100 (3.95)	113 (4.45)	75 (2.95)	88 (3.45)	88 (3.45)	100 (3.95)	113 (4.45)
C	mm (in)	5 (0.2)	134 (5.3)	132 (5.2)	134 (5.3)	160 (6.3)	197 (7.8)	160 (6.3)	157 (6.1)	160 (6.3)	185 (7.3)	197 (7.8)
D	mm (in)	8 (0.3)	246 (9.7)	259 (10.2)	259 (10.2)	284 (11.2)	322 (12.7)	272 (10.7)	284 (11.2)	284 (11.2)	310 (12.2)	322 (12.7)
E	mm (in)	18 (0.7)	916 (36.1)	932 (36.7)	932 (36.7)	957 (37.7)	995 (39.2)	941 (37.1)	958 (37.7)	958 (37.7)	983 (38.7)	995 (39.2)
EM	mm (in)	19 (0.75)	917 (36.1)	933 (36.7)	933 (36.7)	958 (37.7)	996 (39.2)	942 (37.1)	959 (37.8)	959 (37.8)	984 (38.7)	996 (39.2)
F	mm (in)	10 (0.4)	368 (14.5)	381 (15.0)	381 (15.0)	406 (16.0)	445 (17.5)	394 (15.5)	406 (16.0)	406 (16.0)	432 (17.0)	445 (17.5)
H	mm (in)	18 (0.7)	351 (13.8)	364 (14.3)	364 (14.3)	390 (15.3)	428 (16.9)	X X	X X	X X	X X	X X
HB	mm (in)	0.3 (0.1)	73 (2.9)	85 (3.4)	85 (3.4)	98 (3.9)	111 (4.4)	X X	X X	X X	X X	X X
HC	mm (in)	5 (0.2)	134 (5.3)	132 (5.2)	135 (5.3)	160 (6.3)	199 (7.8)	X X	X X	X X	X X	X X
HD	mm (in)	10 (0.4)	162 (6.4)	175 (6.9)	175 (6.9)	200 (7.9)	238 (9.4)	X X	X X	X X	X X	X X
J	mm (in)	10 (0.4)	380 (15)	393 (15.5)	393 (15.5)	418 (16.5)	456 (18)	405 (16)	418 (16.5)	418 (16.5)	444 (17.5)	456 (18)
L	mm (in)	10 (0.4)	338 (13.3)	351 (13.8)	351 (13.8)	376 (14.8)	414 (16.3)	363 (14.3)	376 (14.8)	376 (14.8)	401 (15.8)	414 (16.3)
M	mm (in)	8 (0.3)	516 (20.3)	X X	X X	X X	X X	516 (20.3)	X X	X X	X X	X X
N	mm (in)	10 (0.4)	278 (11)	292 (11.5)	292 (11.5)	318 (12.5)	355 (14)	305 (12)	318 (12.5)	318 (12.5)	243 (13.5)	355 (14)

PROFILE HPGe Photon Detector Product Configuration Guide

**Note: Cryostat/Dewar drawings are NOT to scale, see tables that follow for complete dimensions.
Dimensions are for reference only and subject to change, if dimensional constraints are critical, contact the factory.**

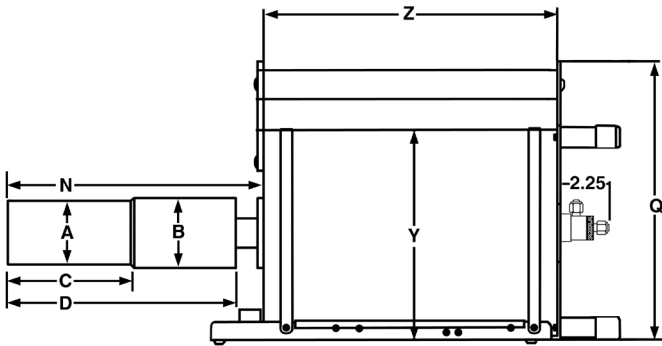

**CFG-PG4-1.2 (or -3 or -5) or
CFG-GG, DWR-1.2G (or -3.0G, -5.0G)**

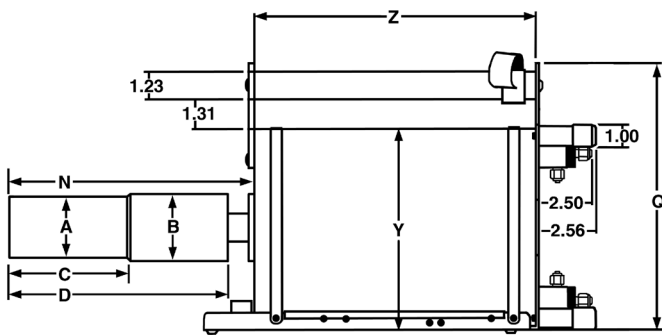

**CFG-PMOD4-3 (or -7) or
CFG-GG, DWR-MOD3L (or -MOD7L)**

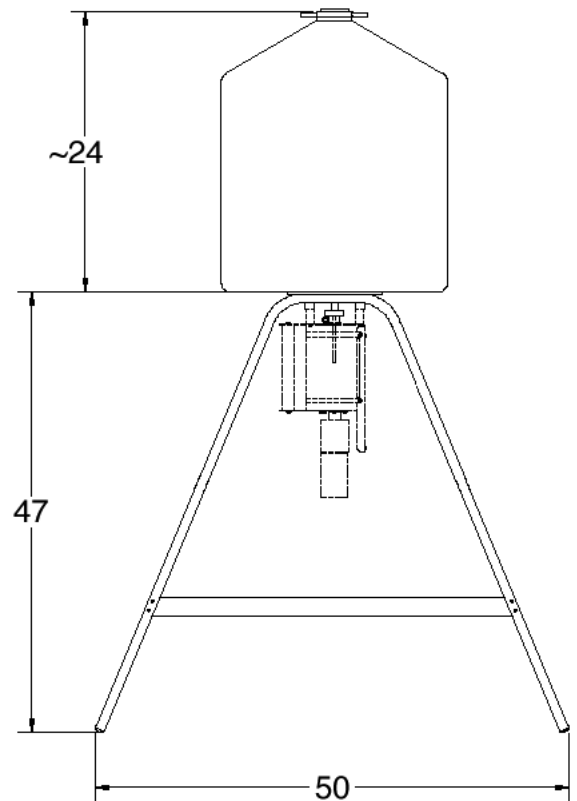

DWR-S/F

Gamma Gage and Side-Looking Dewar Dimensions

- Dimensions are for reference only and subject to change.
- If dimensional constraints are critical, contact the factory.

			Cryostat/Dewar or Dewar Type							
			CFG-PG4 and DWR-x.xG			CFG-PMOD4 and DWR-MOD-xL		CFG-PS4, CFG-PD4, DWR-xxB and DWR-xxD		
			VOLUME			VOLUME		VOLUME		
Dim.	Unit	Tol. ±	1.2L	3L	5L	3L	7L	7.5L	13L	30L
Q	mm (in)	13 (0.5)	229 (9.0)	302 (11.9)	302 (11.9)	229 (9.0)	302 (11.9)	X X	X X	X X
R	mm (in)	10 (0.4)	X X	X X	X X	X X	X X	174 (6.9)	174 (6.9)	155 (6.1)
S	mm (in)	7.6 (0.3)	X X	X X	X X	X X	X X	77 (3.0)	77 (3.0)	60 (2.3)
T	mm (in)	5 (0.2)	X X	X X	X X	X X	X X	10 (0.4)	10 (0.4)	13 (0.5)
Y	mm (in)	13 (0.5)	157 (6.2)	229 (9.0)	229 (9.0)	157 (6.2)	229 (9.0)	224 (8.8)	307 (12.1)	442 (17.4)
Z	mm (in)	5 (0.2)	229 (9.0)	267 (10.5)	419 (16.5)	292 (11.5)	320 (12.6)	452 (17.8)	429 (16.9)	610 (24.0)

PROFILE HPGe Photon Detector Product Configuration Guide

**Note: Cryostat/Dewar drawings are NOT to scale, see tables that follow for complete dimensions.
Dimensions are for reference only and subject to change, if dimensional constraints are critical, contact the factory.**

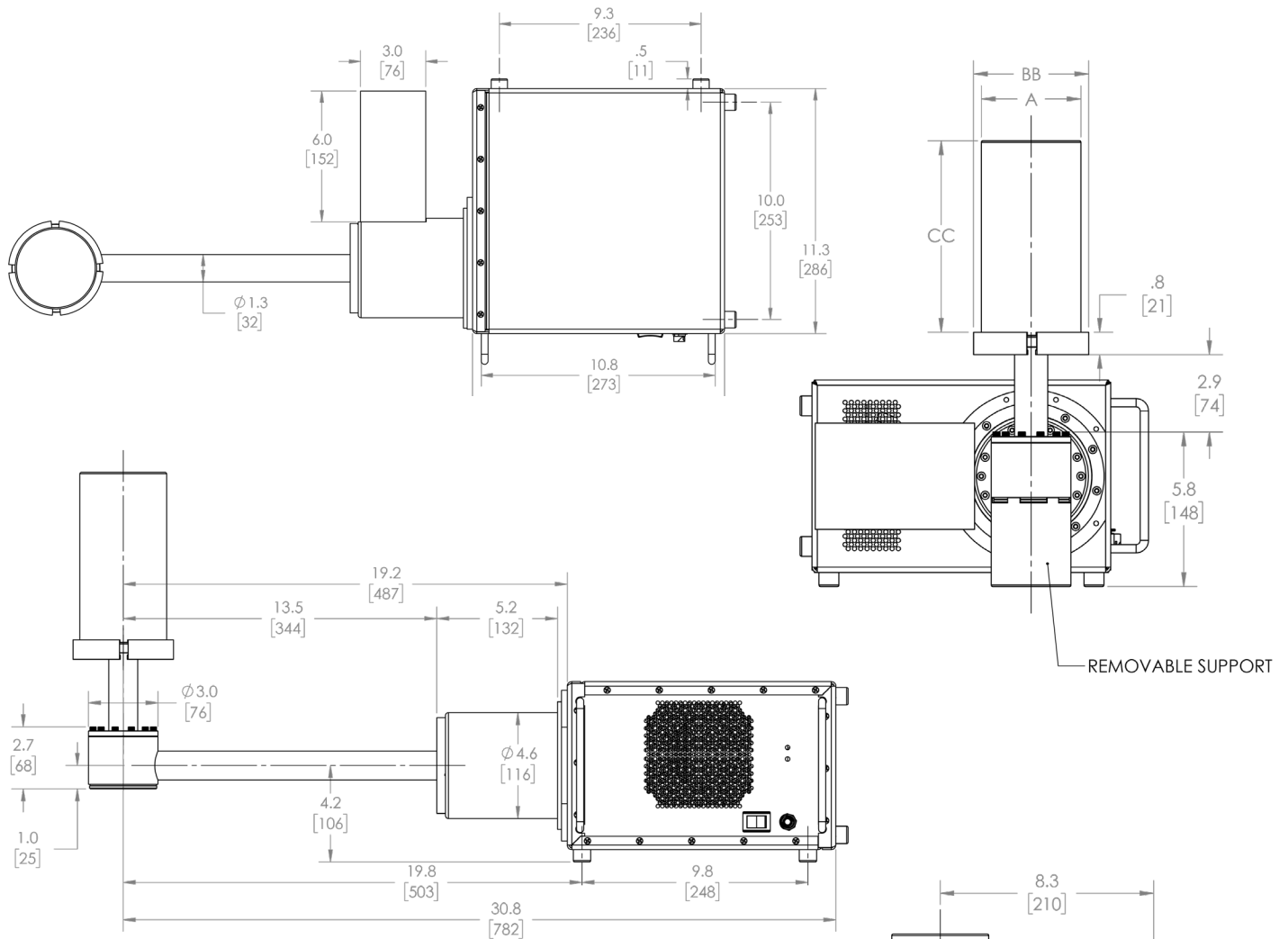

ICS-HJ PROFILE Detector Dimensions			-70	-76	-83	-95	-108
Endcap Model (dia. mm)							
Dim.	Unit	Tol.					
A	mm (in)	0.3 (0.01)	70 (2.75)	76 (3.0)	83 (3.25)	95 (3.75)	108 (4.25)
BB	mm (in)	0.3 (0.01)	85 (3.4)	92 (3.6)	98 (3.9)	111 (4.4)	124 (4.9)
CC	mm (in)	5 (0.2)	145 (5.7)	158 (6.2)	158 (6.2)	183 (7.2)	183 (7.2)

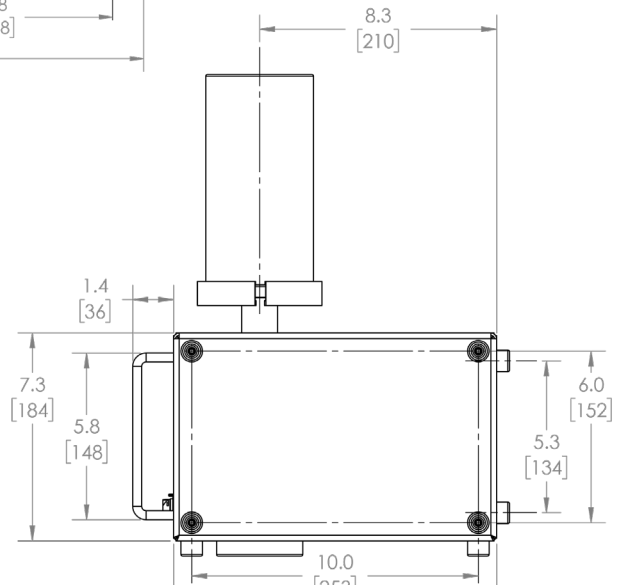

PROFILE HPGe Photon Detector Product Configuration Guide

**Note: Cryostat/Dewar drawings are NOT to scale, see tables that follow for complete dimensions.
Dimensions are for reference only and subject to change, if dimensional constraints are critical, contact the factory.**

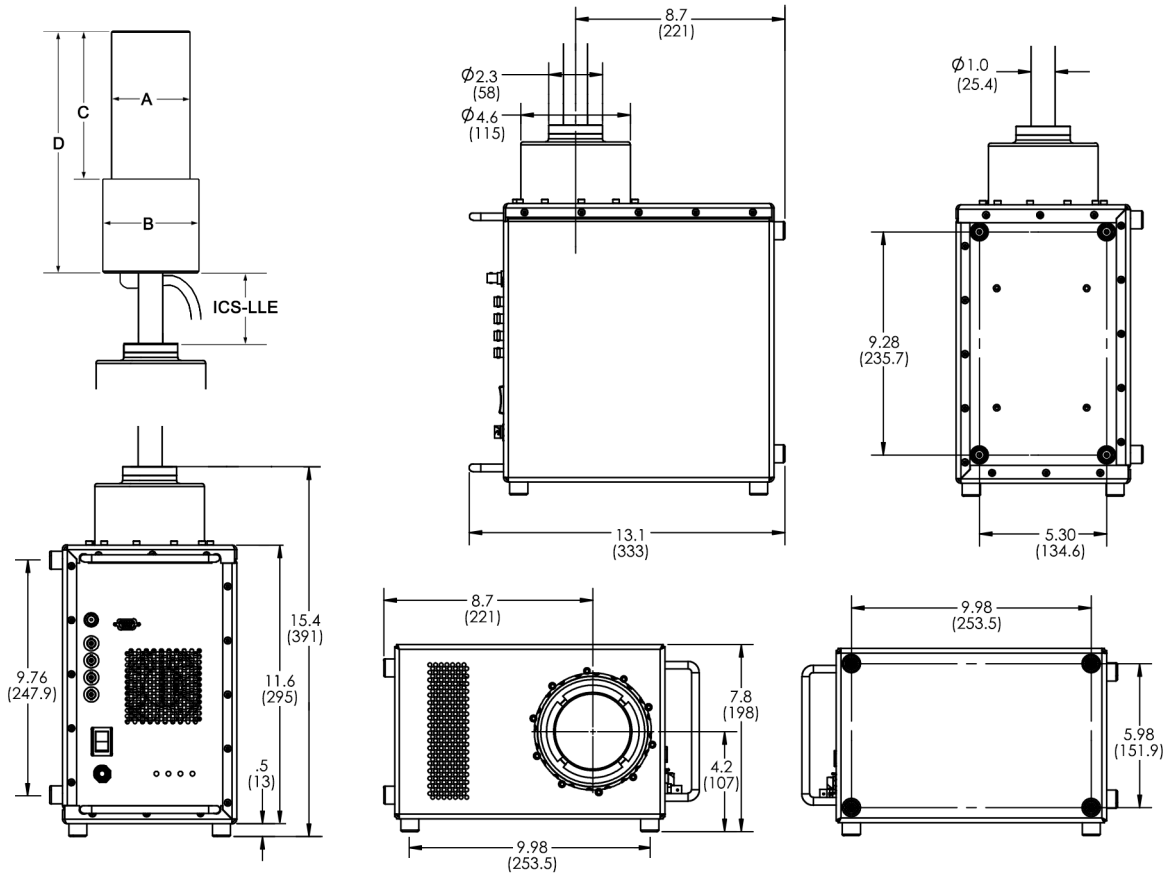

CFG-ICS-E

Streamline PROFILE Detector Dimensions for ICS-E Integrated Cryocooling System

- Dimensions are for reference only and subject to change.
- If dimensional constraints are critical, contact the factory.

S Series Detectors					
Endcap Model (dia. mm)			-70	-83	-108
Dim.	Unit	Tol.			
A	mm (in)	0.3 (0.01)	70 (2.75)	83 (3.25)	108 (4.25)
B	mm (in)	0.3 (0.01)	101 (4.0)	101 (4.0)	127 (5.0)
C	mm (in)	5 (0.2)	127 (5.0)	127 (5.0)	127 (5.0)
D	mm (in)	5 (0.2)	226 (8.9)	226 (8.9)	226 (8.9)
ICS-LLE	mm	3	Specify length. Choose from 025, 114, 139, 190*		

M and C Series Detectors							
Endcap Model (dia. mm)			-70	-76	-83	-95	-108
Dim.	Unit	Tol.					
A	mm (in)	0.3 (0.01)	70 (2.75)	76 (3.0)	83 (3.25)	95 (3.75)	108 (4.25)
B	mm (in)	0.3 (0.01)	101 (4.0)	101 (4.0)	101 (4.0)	114 (4.4)	127 (5.0)
C	mm (in)	5 (0.2)	144 (5.7)	157 (6.2)	157 (6.2)	182 (7.2)	182 (7.2)
D	mm (in)	5 (0.2)	243 (9.6)	256 (10.1)	256 (10.1)	281 (11.1)	281 (11.1)
ICS-LLE	mm	3	Specify length. Choose from 025, 114, 139, 190*				

*Recommended cooling rod length (ICS-LLE): 139 mm for use with 4" lead shield; 190 mm for use with 6" lead shield. Other lengths available by special order.

PROFILE HPGe Photon Detector Product Configuration Guide

Defining the Detector Model

• See ordering information for option compatibility.

Base Model (example)	PopTop or Streamline	ICS Option (if required)	Window Option (if required)	Preamplifier Option (if required)	High Voltage Option (if required)
GEM-M5970	P4 (PopTop) (Streamline)	-ICS-E -ICS-HJ -ICS-LB-HJ	-RB -LB-C -XLB-C	-PL -HJ	-SMP

Example Model Numbers

PopTop Configuration

GEM-C20 CFG-PG4-1.2	50 mm x 60 mm GEM-C detector with 70-mm diameter endcap. Portable Gamma Gage cryostat with 1.2 liter all-position dewar.
GEM-M8295P4-SMP CFG-PD4-7.5	82 mm x 95 mm GEM-M detector with 95-mm diameter endcap and SMART-1 preamp and HV supply. Downlooking cryostat with 7.5 liter dewar.
GEM-M7080P4-RB-SMP CFG-PV4 DWR-30	70 mm x 80 mm GEM-M detector with 83-mm diameter reduced background carbon fiber endcap and SMART-1 preamp HV supply. Vertical “dipstick” style cryostat. 30 liter top port dewar that accepts “dipstick” style cryostats.
GEM-SP5825P4 CFG-ICS-P4	58 mm x 25 mm GEM-SP detector with 70-mm diameter endcap. Integrated Cryocooling System.

Streamline Configuration

GEM-M5970 CFG-GG-70 DWR-1.2G	59 mm x 70 mm GEM-M detector with 70-mm diameter endcap. Portable Gamma Gage cryostat with matching 70-mm diameter flange. 1.2 liter all-position dewar for Gamma Gage cryostat.
GEM-SP5020-SMP CFG-SD-70 DWR-7.5D	50 mm x 20 mm GEM-SP detector with 70-mm diameter endcap and SMART-1 preamp and HV supply. Downlooking cryostat with matching 70-mm diameter flange. 7.5 liter downlooking dewar for downlooking cryostat.
GEM-S7025-HJ CFG-HJ-83 DWR-30B	70 mm x 25 mm GEM-S detector with 83-mm diameter endcap and remote preamp and HV filter. “J” configuration cryostat with remote fittings for the preamplifier and high voltage filter. 30 liter side port dewar for “HJ” cryostat.
GEM-C35-LB-C-PL CFG-SV-70-LB DWR-30	57 mm x 75 mm GEM-C detector with 70-mm diameter low-background carbon fiber endcap, and Plus preamplifier. Vertical “dipstick” style cryostat with 70-mm diameter endcap and low background charcoal pumping agent. 30 liter top port dewar that accepts “dipstick” style cryostats.

Streamline with Integrated Cryocooling System (ICS) Configuration

GEM-S8530-ICS-E CFG-ICS-E ICS-LLE114-108	85 mm x 30 mm GEM-S detector with 108-mm diameter endcap in an ICS integrated cryocooling system with external preamp. Integrated Cryocooling System with external preamp. 114-mm cooling rod length with matching 108-mm diameter flange.
GEM-C55-ICS-E-SMP CFG-ICS-E ICS-LLE025-83	69 mm x 70 mm GEM-C detector with 83-mm diameter endcap in an ICS integrated cryocooling system with external preamp, SMART-1 preamplifier and high voltage supply. Integrated Cryocooling System with external preamp. 25-mm cooling rod length with matching 83-mm diameter flange.
GEM-S5825-ICS-HJ	58 mm x 25 mm GEM-S detector with 70-mm diameter endcap in an ICS-HJ integrated cryocooling system with remote preamp and high voltage filter.
GEM-SP8530-ICS-LB-HJ	85 mm x 30 mm GEM-SP detector with 108-mm diameter endcap in an ICS-LB-HJ integrated cryocooling low-background system with remote preamp and high voltage filter, low-background high purity aluminum endcap and OFHC Cu mount.

PROFILE HPGe Photon Detector

Product Configuration Guide

PROFILE Series GEM Detector Ordering Information and Warranted Specifications

- Cryostat and dewar or other cooling device are not included with detector and are required for operation.
- A cryostat must be ordered with a Streamline detector.
- GEM-M and GEM-C are optimized for use with samples in front of the detector such as filters, Petri dishes, bottles or Marinelli Beakers: Choose the largest diameter which will fit within the Marinelli well.
- GEM-S and GEM-SP are optimized for “close geometry” samples such as filters, Petri dishes, and bottles. If possible, choose a crystal diameter >20% larger than your sample.
- Monte Carlo drawing and certified factory test results are included.

Base Model No.	Crystal Dimensions		Energy Resolution (FWHM)					Peak Shape		Peak to Compton Minimum	Typical Relative Efficiency (%)	Endcap Diameter (mm)
	Actual Diameter +0/-2 mm	Actual Length Min	@ 5.9 keV Maximum (eV) [§]	@ 14.4 keV Typical (eV) [§]	@ 46 keV Typical (eV)	@ 122 keV Maximum (eV)	@ 1.33 MeV Maximum (keV)	FW.1M/ FWHM Typical	FW.02M/ FWHM Typical			
GEM-M5060	50	60				875	1.8	1.90	2.55	60	20	70
GEM-M5970	59	70				900	1.8	1.90	2.65	62	38	70
GEM-M7080	70	80				950	1.9	2.00	3.00	75	66	83
GEM-M8295	82	95				1300	2.1	2.00	3.10	85	115	95
GEM-M94100	94	100				1300	2.3	2.00	3.10	90	175	108
GEM-S5020	50	20	400	500	525	650	1.8	1.90	2.55	35	7	70
GEM-S5825	58	25	425	500	550	650	1.8	1.90	2.65	35	15	70
GEM-S7025	70	25	450	550	575	650	1.9	1.95	2.75	40	20	83
GEM-S7030	70	30	450	550	600	700	1.9	2.00	2.90	40	28	83
GEM-S8530	85	30	500	575	625	700	1.9	2.00	2.90	55	50	108
GEM-S9430	94	30	500	575	650	700	1.9	2.00	2.90	65	65	108
GEM-SP5020	50	20	300	350		585	1.8	1.90	2.55	35	7	70
GEM-SP5825	58	25	340	375		585	1.8	1.90	2.65	35	15	70
GEM-SP7025	70	25	380	400		585	1.8	1.95	2.75	40	20	83
GEM-SP8530	85	30	400	425		630	1.9	2.00	2.90	55	50	108
GEM-SP9430	94	30	425	450		630	1.9	2.00	2.90	65	65	108

Notes

- 1) FWHM = Full Width at Half Maximum; FW.1M = Full Width at One-Tenth Maximum; FW.02M = Full Width at One-Fiftieth Maximum; total system resolution measured at the factory in accordance with ANSI/IEEE Std. 325-1996.
- 2) Measured at optimal shaping time using an ORTEC DSPEC-50A.
- 3) The proprietary contact employed in the S-, SP- and C-Series detectors offer exceptionally high transmission at energies below 40 keV. While the best practice is to keep a germanium detector cold, warm storage will not degrade the transmission efficiency from the front contact.
- 4) Guaranteed resolution performance may degrade with electromechanical or hybrid coolers. Check the cooler brochure for details about guaranteed performance.
- §) Only applies to detectors equipped with carbon fiber windows.
- *) Diameter tolerance +0/-2.

PROFILE HPGe Photon Detector Product Configuration Guide

Base Model No.	Crystal Dimensions		Energy Resolution (FWHM)				Peak Shape		Peak to Compton Minimum	Minimum Relative Efficiency (%)	Endcap Diameter (mm)
	Actual Diameter +2/-2 mm	Actual Length Min	@ 5.9 keV Maximum (eV) [§]	@ 14.4 keV Typical (eV) [§]	@ 122 keV Maximum (eV)	@ 1.33 MeV Maximum (keV)	FW.1M/ FWHM Typical	FW.02M/ FWHM Typical			
GEM-C10	50	25	600	700	800	1.8	1.9	2.55	41	10	70
GEM-C15	50	44	635	735	820	1.8	1.9	2.55	46	15	70
GEM-C20	50	60	650	750	820	1.8	1.9	2.55	52	20	70
GEM-C25	57	50	690	775	850	1.8	1.9	2.60	56	25	70
GEM-C30	57	62	715	775	850	1.8	1.9	2.60	60	30	70
GEM-C35	57	75	730	800	850	1.8	1.9	2.60	62	35	70
GEM-C40	64*	58	760	800	870	1.8	1.9	2.60	64	40	76
GEM-C45	64*	68	800	825	900	1.8	1.9	2.60	64	45	76
GEM-C50	68	62	800	825	900	1.9	1.9	2.60	66	50	83
GEM-C55	68	70	830	925	1000	1.9	1.9	2.60	67	55	83
GEM-C60	68	77	830	925	1000	1.9	1.9	2.80	70	60	83
GEM-C65	68	86	830	925	1000	1.9	1.9	3.00	73	65	83
GEM-C70	70*	85	900	950	1000	2.0	1.9	3.00	75	70	83
GEM-C75	80	56	900	950	1000	2.0	1.9	3.00	73	75	95
GEM-C80	80	61	950	950	1000	2.0	1.9	3.00	73	80	95
GEM-C90	80	70	950	1025	1100	2.0	1.9	3.00	80	90	95
GEM-C100	80	82	1000	1050	1100	2.1	1.9	3.00	83	100	95
GEM-C110	80	91	1050	1075	1100	2.1	1.9	3.00	85	110	95
GEM-C120	82*	98	1050	1075	1100	2.1	1.9	3.00	86	120	95
GEM-C130	92	67	1100	1160	1200	2.1	2.0	3.10	83	130	108
GEM-C140	92	74	1100	1160	1200	2.2	2.0	3.10	83	140	108
GEM-C150	92	81	1100	1250	1300	2.3	2.0	3.10	90	150	108
GEM-C175	94*	100	1100	1250	1300	2.3	2.0	3.10	90	175	108

- Notes**
- 1) FWHM = Full Width at Half Maximum; FW.1M = Full Width at One-Tenth Maximum; FW.02M = Full Width at One-Fiftieth Maximum; total system resolution measured at the factory in accordance with ANSI/IEEE Std. 325-1996.
 - 2) Measured at optimal shaping time using an ORTEC DSPEC-50A.
 - 3) The proprietary contact employed in the S-, SP- and C-Series detectors offer exceptionally high transmission at energies below 40 keV. While the best practice is to keep a germanium detector cold, warm storage will not degrade the transmission efficiency from the front contact.
 - 4) Guaranteed resolution performance may degrade with electromechanical or hybrid coolers. Check the cooler brochure for details about guaranteed performance.
 - §) Only applies to detectors equipped with carbon fiber windows.
 - *) Diameter tolerance +0/-2.

PROFILE HPGe Photon Detector

Product Configuration Guide

PROFILE Detector Options

• Append model to detector model number.

Model No.	Description
P4	<u>PopTop Only</u> . PopTop capsule, add "P4" to the model number.
-RB	<u>PopTop Only</u> . Reduced background PopTop capsule with Carbon Fiber endcap, add "-RB" to the model number.
-LB-C	<u>Streamline Only</u> . Low-Background Detector with Carbon Fiber Endcap, add "-LB-C" to the model number. Requires selection of a Low-Background LB cryostat.
-XLB-C	<u>Streamline Only</u> . Extra-Low-Background Detector with Carbon Fiber Endcap, add "-XLB-C" to the model number. Requires selection of a Low-Background XLB cryostat.
-HJ	<u>Streamline Only</u> . Remote preamplifier and high voltage filter for use with HJ type cryostat, add "-HJ" to the model number. Requires selection of HJ cryostat. Not compatible with -PL or -SMP options.
-ICS-E	<u>ICS Streamline Only</u> . Integrated Cryocooling System with external preamp. Cryostat sealed with a cryocooler and immune to thermal short cycling, add "-ICS-E" to the model number. Requires selection of an ICS-E cryostat. Contact Factory for availability with GEM-SP.
-ICS-HJ	<u>ICS Streamline Only</u> . Integrated Cryocooling System with remote preamp and high voltage filter. Includes Al entrance window. Cryostat sealed with a cryocooler and immune to thermal short cycling, add "-ICS-HJ" to the model number. This option is inclusive of cryostat and does not require selection of an additional cryostat. Not compatible with other options or GEM-SP.
-ICS-LB-HJ	<u>ICS Streamline Only</u> . Integrated Cryocooling System with remote preamp and high voltage filter, High Purity Al Endcap and Cu Mount. Includes Al entrance window. Cryostat sealed with a cryocooler and immune to thermal short cycling, add "-ICS-HJ" to the model number. This option is inclusive of cryostat and does not require selection of an additional cryostat. Not compatible with other options or GEM-S.
-PL	<u>GEM-M and GEM-C Only</u> . PLUS Ultra-high-count-rate Preamplifier, add "-PL" to the model number. Not compatible with -HJ option.
-SMP	SMART-1 detector option for positive bias detector, add "-SMP" to the model number. Not compatible with -HJ option.

PROFILE PopTop Cryostats and Dewars

Model No.	Description
CFG-PD4-7.5	Down-looking Cryostat with 7.5-liter Dewar
CFG-PD4-13	Down-looking Cryostat with 13-liter Dewar
CFG-PD4-30	Down-looking Cryostat with 30-liter Dewar
CFG-PG4-1.2	Gamma Gage Cryostat with 1.2-liter Dewar (for 83 mm or smaller endcaps)
CFG-PG4-3	Gamma Gage Cryostat with 3-liter Dewar
CFG-PG4-5	Gamma Gage Cryostat with 5-liter Dewar
CFG-PH4	Horizontal Cryostat (Dipstick type). Choose DWR-30, DWR-30-OP, MOBIUS-PT or MOBIUS-PT-DET.
CFG-PMOD4-3	Gamma Gage Cryostat with 3-liter Multi-Orientation Dewar
CFG-PMOD4-7	Gamma Gage Cryostat with 7-liter Multi-Orientation Dewar
CFG-PS4-7.5	Side-Looking Cryostat with 7.5-liter Dewar
CFG-PS4-13	Side-Looking Cryostat with 13-liter Dewar
CFG-PS4-30	Side-Looking Cryostat with 30-liter Dewar
CFG-PS4-MOBIUS-B	Side-Looking Cryostat with Möbius Recycler 28-liter Dewar
CFG-PS4-MOBIUS-B-DET	Side-Looking Cryostat with Möbius Recycler 28-liter Dewar for purchase in combination with any PopTop detector.
CFG-PSHP4	Down-Looking Shallow-Hole Probe with 0.7-liter Dewar
CFG-PV4	Vertical Cryostat (Dipstick type). Choose DWR-30, DWR-30-OP, MOBIUS-PT or MOBIUS-PT-DET.
CFG-ICS-P4	Integrated Cryocooling System
MOBIUS-PT	Möbius Recycler.
MOBIUS-PT-DET	Möbius Recycler Dewar for purchase in combination with any PopTop detector and vertical or horizontal dipstick cryostat.
DWR-30	30-liter Dewar. Includes collar for 1.5" diameter cryostat.
DWR-30-OP	30-liter Offset-Port Dewar. Includes collar for 1.5" diameter cryostat.
DWR-S/F	Storage Fill Dewar for CFG-PG4-X

PROFILE HPGe Photon Detector Product Configuration Guide

PROFILE Streamline Cryostats

- May only be purchased with a detector.
- Append matching Detector Endcap Size designation to cryostat model: -70, -76, -83, -95, -108 [e.g., CFG-SJ-95 for GEM-C80, or CFG-SL-XLB-83 for GEM-S7025-XLB-C]
- Dewar required. Select dewar from PROFILE Streamline Dewars.
- Horizontal and Vertical Cryostats include CFG-ADAPTOR to increase cryostat diameter from 1.25 inch to 1.5 inch for use with DWR-30 and DWR-30-OP.

Model No.	Description
CFG-GG	Gamma Gage Cryostat
CFG-HJ	J-type Cryostat with Remote Preamp. (for -HJ option only)
CFG-SD	Down-Looking Cryostat
CFG-SH	Horizontal Cryostat (Dipstick type).
CFG-SJ	J-type Cryostat
CFG-SL	Side-Looking Cryostat
CFG-SV	Vertical Cryostat (Dipstick type).

LOW-BACKGROUND

CFG-GG-LB	Low-Background Gamma Gage Cryostat
CFG-HJ-LB	Low-Background J-type Cryostat with Remote Preamp. (for -HJ option only)
CFG-SD-LB	Low-Background Down-Looking Cryostat
CFG-SH-LB	Low-Background Horizontal Cryostat (Dipstick type).
CFG-SJ-LB	Low-Background J-type Cryostat
CFG-SL-LB	Low-Background Side-Looking Cryostat
CFG-SV-LB	Low-Background Vertical Cryostat (Dipstick type).
CFG-SD-XLB	Extra-Low-Background Down-Looking Cryostat
CFG-SH-XLB	Extra-Low-Background Horizontal Cryostat (Dipstick type).
CFG-SJ-XLB	Extra-Low-Background J-type Cryostat
CFG-SL-XLB	Extra-Low-Background Side-Looking Cryostat
CFG-SV-XLB	Extra-Low-Background Vertical Cryostat (Dipstick type).

PROFILE Streamline Dewars

For Cryostat	Choose	Description
CFG-GG	DWR-1.2G	1.2-liter All-Orientation Dewar
	DWR-3.0G	3.0-liter All-Orientation Dewar
	DWR-5.0G	5.0-liter All-Orientation Dewar
	DWR-MOD-3L	3-liter Multi-Orientation Dewar
	DWR-MOD-7L	7-liter Multi-Orientation Dewar
	DWR-0.7-SHP-G	0.7-liter Shallow-Hole Probe Dewar
	DWR-S/F	Storage/Fill Dewar for DWR-XG
CFG-HJ, SJ, SL	DWR-7.5B	7.5-liter Side-Looking Dewar
	DWR-13B	13-liter Side-Looking Dewar
	DWR-30B	30-liter Side-Looking Dewar
	MOBIUS-B	Möbius Recycler Side-Looking Dewar
CFG-SD	DWR-7.5D	7.5-liter Down-Looking Dewar
	DWR-13D	13-liter Down-Looking Dewar
	DWR-30D	30-liter Down-Looking Dewar
CFG-SV, SH	DWR-30	30-liter Dewar. Includes collar for 1.5" diameter cryostat.
	DWR-30-OP	30-liter Offset-Port Dewar. Includes collar for 1.5" diameter cryostat.
	MOBIUS-ST	Möbius Recycler Dewar for purchase stand alone
	MOBIUS-ST-DET	Möbius Recycler Dewar for purchase in combination with Detector

PROFILE HPGe Photon Detector Product Configuration Guide

PROFILE ICS-E Cryostat

- May only be purchased with a detector.
- Append matching Detector Endcap Size designation to Cooling Rod Length model: -70, -76, -83, -95, -108 [e.g., CFG-ICS-E, ICS-LLE139-70 for GEM-S5020-ICS-E].
- Contact Factory for availability with GEM-SP.

Model	Description
CFG-ICS-E	Integrated Cryocooling System with External Preamp. Cooling Rod Length must be specified ,see below. Cooling Rod Length. Add as separate line item ICS-LLExxx where xxx = one of the following lengths: 025, 114, 139, 190, and append matching Detector Endcap Size [e.g., ICS-LLE190-70].

*Recommended cooling rod length (ICS-LLE): 139 mm for use with 4" lead shield. 190 mm for use with 6" lead shield. Other lengths available by special order.

PROFILE HPGe Photon Detector Product Configuration Guide

PROFILE HPGe Photon Detector Product Configuration Guide



www.ortec-online.com

Tel. (865) 482-4411 ortec.info@ametek.com

801 South Illinois Avenue, Oak Ridge, TN 37830 U.S.A.

Visit Our Website For International Office Locations

Specifications subject to change
24-0506