

**BLACK MAX™ Power Supply
Model 4002E
Operating and Service Manual**

Advanced Measurement Technology, Inc.

a/k/a/ ORTEC[®], a subsidiary of AMETEK[®], Inc.

WARRANTY

ORTEC* warrants that the items will be delivered free from defects in material or workmanship. ORTEC makes no other warranties, express or implied, and specifically NO WARRANTY OF MERCHANTABILITY OR FITNESS FOR A PARTICULAR PURPOSE.

ORTEC's exclusive liability is limited to repairing or replacing at ORTEC's option, items found by ORTEC to be defective in workmanship or materials within one year from the date of delivery. ORTEC's liability on any claim of any kind, including negligence, loss, or damages arising out of, connected with, or from the performance or breach thereof, or from the manufacture, sale, delivery, resale, repair, or use of any item or services covered by this agreement or purchase order, shall in no case exceed the price allocable to the item or service furnished or any part thereof that gives rise to the claim. In the event ORTEC fails to manufacture or deliver items called for in this agreement or purchase order, ORTEC's exclusive liability and buyer's exclusive remedy shall be release of the buyer from the obligation to pay the purchase price. In no event shall ORTEC be liable for special or consequential damages.

Quality Control

Before being approved for shipment, each ORTEC instrument must pass a stringent set of quality control tests designed to expose any flaws in materials or workmanship. Permanent records of these tests are maintained for use in warranty repair and as a source of statistical information for design improvements.

Repair Service

If it becomes necessary to return this instrument for repair, it is essential that Customer Services be contacted in advance of its return so that a Return Authorization Number can be assigned to the unit. Also, ORTEC must be informed, either in writing, by telephone [(865) 482-4411] or by facsimile transmission [(865) 483-2133], of the nature of the fault of the instrument being returned and of the model, serial, and revision ("Rev" on rear panel) numbers. Failure to do so may cause unnecessary delays in getting the unit repaired. The ORTEC standard procedure requires that instruments returned for repair pass the same quality control tests that are used for new-production instruments. Instruments that are returned should be packed so that they will withstand normal transit handling and must be shipped PREPAID via Air Parcel Post or United Parcel Service to the designated ORTEC repair center. The address label and the package should include the Return Authorization Number assigned. Instruments being returned that are damaged in transit due to inadequate packing will be repaired at the sender's expense, and it will be the sender's responsibility to make claim with the shipper. Instruments not in warranty should follow the same procedure and ORTEC will provide a quotation.

Damage in Transit

Shipments should be examined immediately upon receipt for evidence of external or concealed damage. The carrier making delivery should be notified immediately of any such damage, since the carrier is normally liable for damage in shipment. Packing materials, waybills, and other such documentation should be preserved in order to establish claims. After such notification to the carrier, please notify ORTEC of the circumstances so that assistance can be provided in making damage claims and in providing replacement equipment, if necessary.

Copyright © 2002, Advanced Measurement Technology, Inc. All rights reserved.

*ORTEC[®] is a registered trademark of Advanced Measurement Technology, Inc. All other trademarks used herein are the property of their respective owners.

CONTENTS

WARRANTY	ii
SAFETY INSTRUCTIONS AND SYMBOLS	iv
SAFETY WARNINGS AND CLEANING INSTRUCTIONS	v
1. DESCRIPTION	1
2. SPECIFICATIONS	1
3. INSTALLATION	2
3.1. UNPACKING	2
3.2. SELECTING THE MAINS VOLTAGE	2
3.3. CONNECTION OF THE 4002E TO A NIM BIN	3
3.3.1. Requirements for Attached Bin	3
3.3.2. Instructions for Attaching Bin	3
4. OPERATING INSTRUCTIONS	5
5. MAINTENANCE	5
5.1. FACTORY REPAIR	5

SAFETY INSTRUCTIONS AND SYMBOLS

This manual contains up to three levels of safety instructions that must be observed in order to avoid personal injury and/or damage to equipment or other property. These are:

- DANGER** Indicates a hazard that could result in death or serious bodily harm if the safety instruction is not observed.
- WARNING** Indicates a hazard that could result in bodily harm if the safety instruction is not observed.
- CAUTION** Indicates a hazard that could result in property damage if the safety instruction is not observed.

Please read all safety instructions carefully and make sure you understand them fully before attempting to use this product.

In addition, the following symbol may appear on the product:



ATTENTION—Refer to Manual

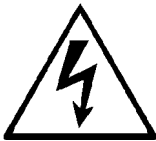

DANGER—High Voltage

Please read all safety instructions carefully and make sure you understand them fully before attempting to use this product.

SAFETY WARNINGS AND CLEANING INSTRUCTIONS

DANGER Opening the cover of this instrument is likely to expose dangerous voltages. Disconnect the instrument from all voltage sources while it is being opened.

WARNING Using this instrument in a manner not specified by the manufacturer may impair the protection provided by the instrument.

Cleaning Instructions

To clean the instrument exterior:

- Unplug the instrument from the ac power supply.
- Remove loose dust on the outside of the instrument with a lint-free cloth.
- Remove remaining dirt with a lint-free cloth dampened in a general-purpose detergent and water solution. Do not use abrasive cleaners.

CAUTION To prevent moisture inside of the instrument during external cleaning, use only enough liquid to dampen the cloth or applicator.

- Allow the instrument to dry completely before reconnecting it to the power source.

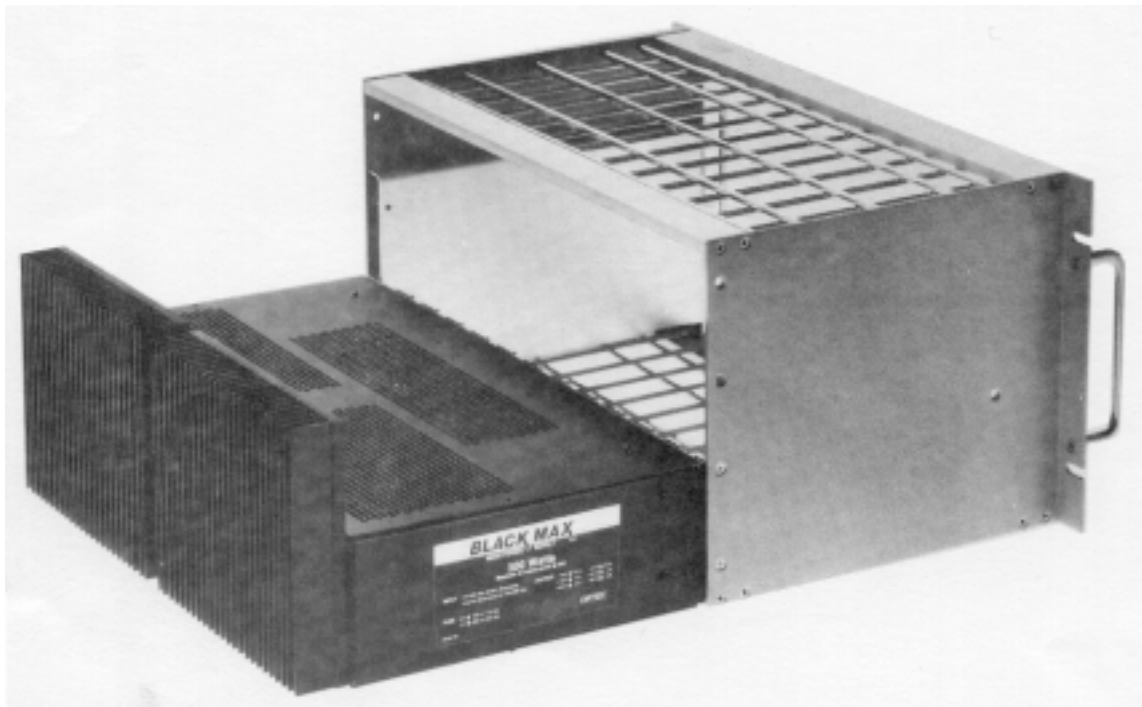
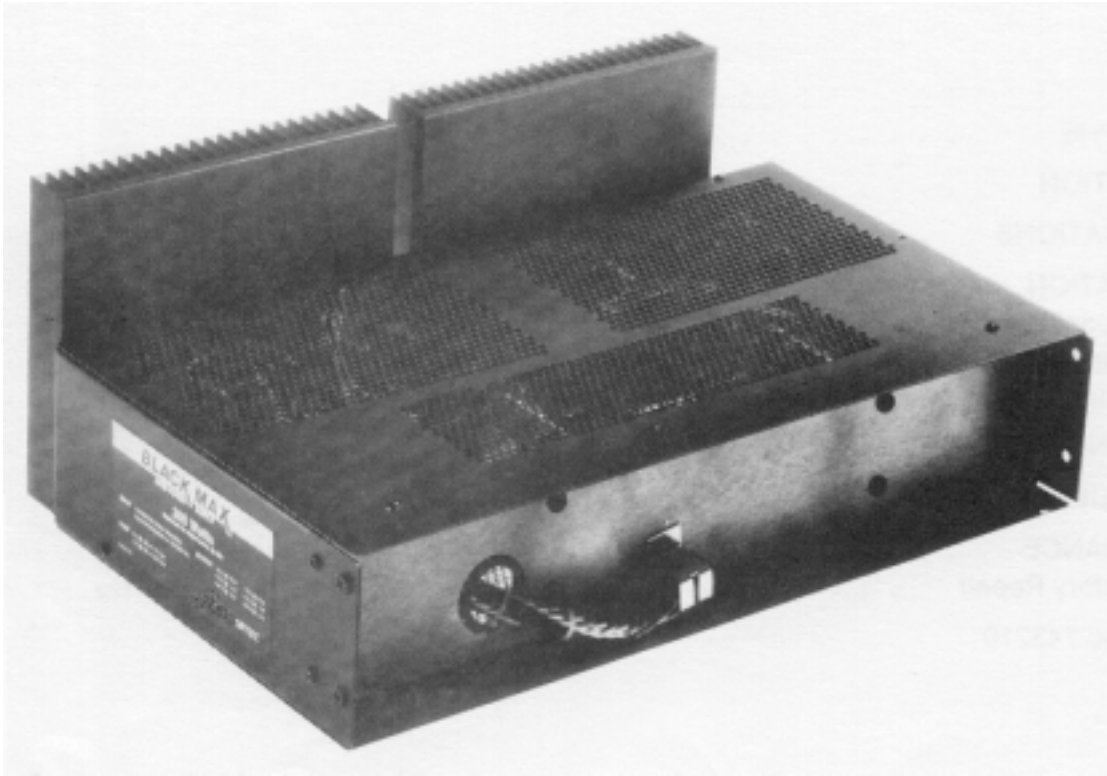

ORTEC MODEL 4002E BLACK MAX™ POWER SUPPLY

1. DESCRIPTION

The ORTEC Model 4002E BLACK MAX™ Power Supply is designed to supply dc power to a NIM Bin when the application demands exceptionally high power. The BLACK MAX Power Supply can be purchased separately for use with existing NIM Bins, or it can be ordered attached to a 4001C NIM Bin. Mounting hardware is supplied to make the Model 4002E compatible with all ORTEC NIM Bins. With minor mounting modifications the 4002E can be used with most standard NIM Bins. The ORTEC 4001C NIM Bin is recommended for use with the 4002E because the 4001C distributes the power with copper bus bars to minimize the voltage drop at each module's power plug. The BLACK MAX Power Supply is designed to exceed recommended power supply specifications for Type V-H supplies as defined in DOE/ER-0457T.

Regulated dc power supplied to the attached bin by the BLACK MAX is conservatively rated at +6 V @ 12 A, -6V@12A, +12V@4A, -12V@4A, +24V@ 2 A, and -24 V @2A, provided the total output dc power does not exceed 300 W at ambient temperatures up to 50°C. In addition, 115 V ac is available up to 0.5 A.

Protection against overload is provided in several ways. When the heat sink temperature exceeds 95°C, the red warning indicator is illuminated on the

attached bin control panel. When the heat sink temperature exceeds 110°C, the power supply is automatically shut down, causing both the power and temperature indicator lights to turn off. Recovery from thermal overload is automatic when the thermal load is reduced. Output currents from the dc supplies are internally limited to 120% of their rated values by foldback circuits. This provides overload and short-circuit protection. On the +6 V and -6 V dc supplies, crowbar circuits limit the output voltage to 7.5 V to protect integrated circuits. Fuses protect the ac inputs to the power supply.

An external slide switch allows selection of either 115 or 220 V ac as the power input. By changing pins on an internal connector, this selection can be altered to 100 and 200 V ac. An international standard IEC power connector permits power cords and plugs that meet local electrical standards to be used for the input power. Control of the primary power is provided by the On/Off switch on the NIM Bin control panel.

Connection of power and control lines to the NIM Bin is provided by the standard interface connector specified in DOE ER-0457T. Mechanical mounting of the power supply to the bin is with brackets utilizing the standard bolt pattern specified in DOE/ER-0457T.

2. SPECIFICATIONS

INPUT 103–129 or 200–258 V ac, 47–63 Hz. An external slide switch selects nominal input voltages of 115 or 220 V ac. Changing pins on an internal connector allows operation at 88-110 V or 191–239 V ac, 47–63 Hz, with the external slide switch selecting nominal voltages of 100 or 200 V ac. Input current at 115 V ac is nominally 7 A for a 300-W dc output simultaneous with a 0.5-A, 115-V ac output. Dual fuse input uses 8-A SB U.S.A. standard fuses for 100 or 115 V ac, 60 Hz and 5-A SB metric fuses for 200 and 220 V ac, 50 Hz operation.

DC OUTPUTS Maximum rated output currents are:

DC Voltage	Maximum Current	DC Voltage	Maximum Current
+6 V	12 A	-6 V	12 A
-12 V	4 A	-12 V	4 A
+24 V	2 A	-24 V	2 A

Maximum dc output power from 0 to 50°C is 300 W. Derate 3%/°C for 50 to 60°C.

115 V ac OUTPUT Unregulated voltage. Maximum current limited only by the input fuses when operated in the 100- or 115-V ac settings. Limited to 0.5 A on the 200- and 220-V ac settings when the dc load is 300 W. Output voltage is nominally 115 V ac in the 115-V and 220-V input modes. Output voltage is nominally 100 V ac in the 100-V and 200-V input modes.

REGULATION $<\pm 0.1\%$ (typically $\pm 0.05\%$) for ± 12 V and ± 24 V, and $<\pm 0.2\%$ (typically $\pm 0.1\%$) for ± 6 V over the combined range of zero to full load with the specified input voltage range for measurements made within a 1-minute period. Regulation $<\pm 0.3\%$ for ± 12 V and ± 24 V, and $<\pm 0.6\%$ for ± 6 V over any 24-hour period at constant ambient temperature for the same load and input ranges after a 60-minute warmup.

LONG TERM STABILITY DC output voltages change $<\pm 0.5\%$ (after a 60-minute warmup) over a 6-month period at constant load, line voltage, and ambient temperature.

OUTPUT IMPEDANCE $<0.3 \Omega$ at any frequency up to 100 kHz for the dc outputs.

TEMPERATURE COEFFICIENT $<0.02\%/^{\circ}\text{C}$, 0 to 60°C .

NOISE AND RIPPLE <3 mV peak-to-peak for any output as observed on a 50-MHZ bandwidth oscilloscope.

VOLTAGE ADJUSTMENT $\pm 2\%$ minimum range. Resettability $<\pm 0.05\%$ of the supply voltage.

RECOVERY TIME $<100\mu\text{s}$ to return to within $\pm 0.1\%$ of the rated voltage for all dc outputs for any input voltage change within the rated range or for a change of load current from 10% to 100% of full load.

CIRCUIT PROTECTION Both input power lines include fuses. The power supply is automatically turned off by an internal switch if the temperature of the heat sink exceeds 110°C . Recovery is automatic when the temperature decreases to a safe value. Provision is made for activating a temperature warning light on the NIM Bin control panel to advise that the temperature limit is being approached. This warning occurs at and above a heat sink temperature of 95°C . All dc outputs include a current foldback circuit to limit the output current to nominally 120% of the rated value. This feature provides short-circuit and overload protection. Recovery is automatic after removal of the overload condition. Over-voltage protection for the ± 6 -V outputs prevents these outputs from exceeding ± 7.5 V, respectively, to protect the integrated circuits that are commonly powered by these supply voltages.

WEIGHT 13.6 kg (30 lb) net weight, 18.1 kg (40 lb) shipping weight.

DIMENSIONS 43.2 cm (17.0 in.) wide, 26.9 cm (10.6 in.) deep, and 8.9 cm (3.5 in.) high, except for rear-mounted, 15.2-cm- (6.0-in.-) high heat sink.

3. INSTALLATION

3.1. UNPACKING

Unpack the unit, being careful to retain all packing materials until the unit has been checked for possible concealed damage. The power cord is packed with the unit and attaches to a three-pin connector that is mounted on the rear of the 4002E BLACK MAX Power Supply.

3.2. SELECTING THE MAINS VOLTAGE

The 4002E BLACK MAX Power Supply is designed so that the transformer primary can be connected in a configuration that is compatible with the available

mains voltage. Check the voltage level to be used and select the appropriate range on the 4002E BLACK MAX Power Supply. The normal selection is either 115 V ac or 220 V ac, and the selection is made using the slide switch on the side of the power supply near the power cord. Alternatively, the 4002E BLACK MAX Power Supply can be wired so that the selection can be either 100 V ac or 200 V ac. Modification of the 4002E BLACK MAX Power Supply for 100/200 V ac operation requires exchanging two wires on the primary of the transformer. There are two sections of the transformer; one section has two wires (black,

white) and the other section has three wires (black, white, and black/white). Changes are made to the transformer section that has the three wires.

The following steps are required to modify the 4002E Power Supply for 100/200 V ac operation:

DANGER Opening the cover of this instrument is likely to expose dangerous voltages. Disconnect the instrument from all voltage sources before opening it.

1. Install crimp pin (Part No. 490590) to the black/white wire on the section of the transformer having three wires. (This is the only unused wire on the primary section of the transformers.)
2. Using the proper tool (Part No. 635690), extract the black wire from position 3 of the primary connector wiring housing. NOTE: This black wire must be connected to the same primary section as the black/white wire.
3. Install the black/white wire into position 3 of the primary connector wiring housing.
4. Cover exposed pin of the black wire removed from the primary connector wiring housing with shrink tubing for safety.
5. Install the 100/200 V ac operation label to the chassis near the ac voltage select switch.
6. Install an 8-A (SB) (250V), size 3AG fuse for 100-V or 120-V operation. Install a 5-A (T) (250V), size 5x20-mm fuse in the fuse holder supplied with the power supply for 200-V or 220-V operation.

3.3. CONNECTION OF THE 4002E TO A NIM BIN

The 4002E BLACK MAX Power Supply is normally attached to an ORTEC 4001C Modular System Bin. However, the 4002E is designed to DOE/ER-0457T specifications and may be attached, in the space provided, to any bin manufactured to those specifications.

3.3.1. Requirements for Attached Bin

The 4002E BLACK MAX Power Supply is designed to provide very high currents to NIM modules that contain heavy loads. The NIM Bin used with this

power supply must be capable of handling the large currents demanded by those loads. The power On/Off switch mounted on the bin and its associated primary circuit wiring must be rated to handle 8 A. ORTEC bins that can handle the 8-A primary current have a label inside the bin near the On/Off switch that states "8 A Power Switch." An 8-A Switch Conversion Kit can be ordered from ORTEC as Part No. 735110.

The bin wiring distributing the dc voltages must also have an impedance low enough to yield negligible voltage drops at the rated currents for the supply. Although the ORTEC Model 4001A NIM Bin will function acceptably with the 4002E power supply, the Model 4001C Bin is strongly recommended as the more desirable choice. The ORTEC Model 4001C Bin employs copper bus bars for power distribution. This typically results in more than a factor of 10 lower voltage drop at maximum current.

3.3.2. Instructions for Attaching Bin

For attachment to a bin other than an ORTEC bin, please refer to the appropriate instruction manual. The On/Off switch and other controls necessary to operate the Power Supply are part of the bin and not furnished with the Power Supply.

For attachment to the ORTEC bin, the following steps are advised:

WARNING Always disconnect the power cord at the power supply chassis before connecting or disconnecting the bin-power supply connector (PG13-PG14). Failure to do so will result in a shock hazard at PG14 and can also damage the power supply or the contents of the bin.

1. The adapter blocks used to mount the Power Supply to the bin are shipped attached to the Power Supply. These adapter blocks are polarized and mount in one orientation for ORTEC 4001A and 4001C Bins, and in another orientation for older ORTEC and other manufacturers' bins. One adapter block is marked on top with an "L", and the other adapter block is marked on top with an "R".

2. First remove the adapter blocks from the Power Supply. They will be mounted to the bin and then the Power Supply will be mounted to the adapter blocks.

3. Using the ORTEC 4001A/C Bins, mount the adapter block with an "R" on top to the side of the bin that has the On/Off switch, using two 10-32 screws and lockwashers. Next, mount the adapter block with an "L" on top to the other side of the bin, using two 10-32 screws and lockwashers. Note that the mounting holes in the adapter blocks that are used to mount the Power Supply are closer to the bin than to the Power Supply as shown in Figure 1(A).

4. Place the bin on a table with the back part facing you. Place the power supply in the proper mounting position, leaving enough space between the two pieces to attach the interface connector.

5. After ensuring that the power cord is disconnected, mate the interface connector, being careful to align the polarizing pins. Fold and form all wiring close to the connector edges to prevent any wires from being pinched and producing a short circuit in succeeding steps.

6. Mount the power supply to the adapter blocks by securely tightening the four 1/4-in. black 10-32

screws between the sides of the Power Supply and the adapter blocks, being careful not to pinch any wires or to use undue force on any parts. With the adapter blocks in proper orientation, the side of the Power Supply will closely butt to the back of the bin.

7. When using older ORTEC bins, or those manufactured by other vendors, the orientation of the adapter blocks may need to be changed to ensure that the Power Supply will closely butt to the back of the bin. In this case, mount the adapter block marked with an "L" on top to the side of the bin that has the On/Off switch, using two 10-32 screws and lockwashers. Next, mount the adapter block with an "R" on top to the other side of the bin using two 10-32 screws and lockwashers. Note that the mounting holes in the adapter blocks that are used to mount the Power Supply are closer to the Power Supply than to the bin as shown in Figure 1(B).

8. Perform steps 4, 5, and 6 listed above.

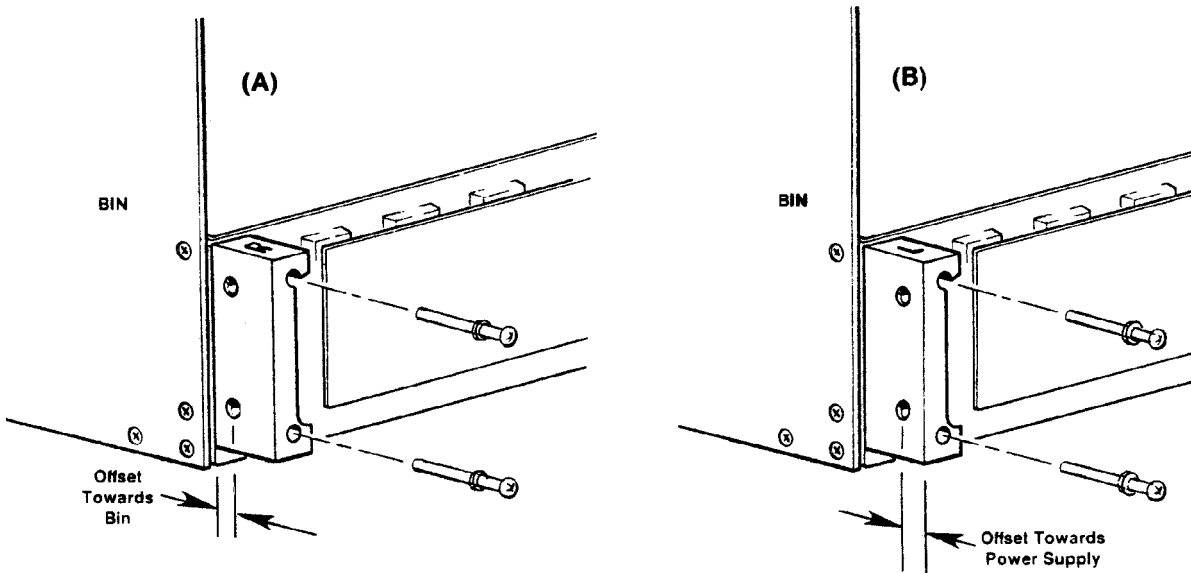

Fig. 1. Bin to Power Supply Block Adapter provides simple installation of bins and power supplies. (A) Illustrates Adapter used with ORTEC 4001A/C Bins. (B) Shows Adapter repositioned for use with earlier ORTEC bins. These conversions are accomplished by exchanging the positions of the two Adapter Blocks on the NIM bin.

4. OPERATING INSTRUCTIONS

The available current from the power supply is specified in Section 2, "DC OUTPUTS." Care must be used to ensure natural convection of heat dissipation by the heat sinks and power transformer. When used at maximum power loading on a bench or tabletop, the bin and power supply should be in an open space, placed upon blocks at least 1 in. off the table mounting surface to allow maximum ventilation. When used in a rack, attention should be paid to placement of other heat-generating equipment. Adequate unobstructed space on all sides is necessary for convection ventilation and cooling. If the bin contains other heat-generating equipment, a blower may be advisable to remove the dissipated heat.

When it is necessary to rack mount several bins and power supplies, especially when other heat-generating equipment is located within the rack, the term "ambient temperature" becomes less clearly defined. A better guide to maximum power loading capability is to monitor the heat sink temperature. Never allow the heat sink temperature to run continuously above 95 C. Although this is not the maximum operating temperature, any additional temperature rise due to other conditions of the system may force the supply out of tolerance and may cause it to automatically shut down operation. Should your operation produce a heat sink temperature of 85 C, a blower to remove the heat is recommended.

5. MAINTENANCE

The 4002E BLACK MAX Power Supply needs no routine maintenance or adjustment. If a problem develops and troubleshooting becomes necessary, the top and bottom screen covers should be removed to provide access to the components.

WARNING While probing inside the 4002E BLACK MAX Power Supply chassis, use extreme caution. There are two shock-hazard locations to regard: the wiring side of the input line cord connector block and the four thermal switches (S1, S2, S3, and S4) mounted against the heat sink. These two locations contain exposed primary circuit conductors.

Most of the components mounted on the heat sink can be replaced fairly easily. If replacement is required, remove power cord and then remove the four mounting screws that hold the inner chassis. Proceed by removing all wire connections associated with the inner chassis components.

Once the inner chassis is removed and out of the way, access to the heat sink components is available. It may also be necessary to remove the two large 10,000- μ F capacitors, C8 and C13, located in the center of the board in order to gain easy access to the diode bridges, D2 and D14, on the heat sink. When replacing a component, be sure to use the same hardware, which includes the thermal pad insulators on the heat sink side of the component, on the replaced components. All replaced heat sink components need to be tightened with a torque wrench to 5 in./lb.

5.1. FACTORY REPAIR

This instrument can be returned to the ORTEC factory for service and repair at a nominal cost. Our standard repair procedures ensure the same quality control and checkout that are used for a new instrument. Always contact the ORTEC Customer Service Department at (865) 482-4411, before returning an instrument for repair, to obtain shipping instructions and the required Return Authorization Number. Write this number on both the address label and package to ensure proper handling when the instrument reaches the factory.

Table 5.1 Typical dc Voltages.

Node	Voltage	Node	Voltage
U1 (1)	24.00	U4 (1)	0
(2)	2.45	(2)	-21.48
(3)	2.46	(3)	-21.59
(4)	2.49	(4)	-21.53
(5)	0	(5)	-24.00
(6)	24.99	(6)	1.19
(7)	0	(7)	-24.00
(8)	35.63	(8)	9.50
(9)	25.53	(9)	1.75
(10)	25.50	(10)	-0.50
U2 (1)	12.00	U5 (1)	6.00
(2)	2.46	(2)	2.45
(3)	2.46	(3)	2.45
(4)	2.50	(4)	2.54
(5)	0	(5)	0
(6)	13.06	(6)	6.94
(7)	0	(7)	0
(8)	35.63	(8)	35.63
(9)	13.62	(9)	7.48
(10)	11.28	(10)	5.67
U3 (1)	0	U6 (1)	0
(2)	-9.54	(2)	-3.55
(3)	-9.56	(3)	-3.55
(4)	-9.54	(4)	-3.49
(5)	-12.00	(5)	-6.00
(6)	1.13	(6)	1.01
(7)	-12.00	(7)	-6.00
(8)	9.50	(8)	9.50
(9)	1.70	(9)	1.56
(10)	-0.72	(10)	-0.34

**Bin/Module Connector Pin Assignments For
Standard Nuclear Instrument Modules
per DOE/ER-0457T.**

Pin	Function	Pin	Function
1	+3 V	23	Reserved
2	- 3 V	24	Reserved
3	Spare bus	25	Reserved
4	Reserved bus	26	Spare
5	Coaxial	27	Spare
6	Coaxial	*28	+24 V
7	Coaxial	*29	- 24 V
8	200 V dc	30	Spare bus
9	Spare	31	Spare
*10	+6 V	32	Spare
*11	- 6 V	*33	117 V ac (hot)
12	Reserved bus	*34	Power return ground
13	Spare	35	Reset (Scaler)
14	Spare	36	Gate
15	Reserved	37	Reset (Auxiliary)
*16	+12 V	38	Coaxial
*17	- 12 V	39	Coaxial
18	Spare bus	40	Coaxial
19	Reserved bus	*41	117 V ac (neutral)
20	Spare	*42	High-quality ground
21	Spare	G	Ground guide pin
22	Reserved		

Pins marked (*) are installed and wired in ORTEC's 4001A and 4001C Modular System Bins.

