

**Model 572A  
Spectroscopy Amplifier  
Operating and Service Manual**

# **Advanced Measurement Technology, Inc.**

a/k/a/ ORTEC<sup>®</sup>, a subsidiary of AMETEK<sup>®</sup>, Inc.

## **WARRANTY**

ORTEC\* warrants that the items will be delivered free from defects in material or workmanship. ORTEC makes no other warranties, express or implied, and specifically NO WARRANTY OF MERCHANTABILITY OR FITNESS FOR A PARTICULAR PURPOSE.

ORTEC's exclusive liability is limited to repairing or replacing at ORTEC's option, items found by ORTEC to be defective in workmanship or materials within one year from the date of delivery. ORTEC's liability on any claim of any kind, including negligence, loss, or damages arising out of, connected with, or from the performance or breach thereof, or from the manufacture, sale, delivery, resale, repair, or use of any item or services covered by this agreement or purchase order, shall in no case exceed the price allocable to the item or service furnished or any part thereof that gives rise to the claim. In the event ORTEC fails to manufacture or deliver items called for in this agreement or purchase order, ORTEC's exclusive liability and buyer's exclusive remedy shall be release of the buyer from the obligation to pay the purchase price. In no event shall ORTEC be liable for special or consequential damages.

## **Quality Control**

Before being approved for shipment, each ORTEC instrument must pass a stringent set of quality control tests designed to expose any flaws in materials or workmanship. Permanent records of these tests are maintained for use in warranty repair and as a source of statistical information for design improvements.

## **Repair Service**

If it becomes necessary to return this instrument for repair, it is essential that Customer Services be contacted in advance of its return so that a Return Authorization Number can be assigned to the unit. Also, ORTEC must be informed, either in writing, by telephone [(865) 482-4411] or by facsimile transmission [(865) 483-2133], of the nature of the fault of the instrument being returned and of the model, serial, and revision ("Rev" on rear panel) numbers. Failure to do so may cause unnecessary delays in getting the unit repaired. The ORTEC standard procedure requires that instruments returned for repair pass the same quality control tests that are used for new-production instruments. Instruments that are returned should be packed so that they will withstand normal transit handling and must be shipped PREPAID via Air Parcel Post or United Parcel Service to the designated ORTEC repair center. The address label and the package should include the Return Authorization Number assigned. Instruments being returned that are damaged in transit due to inadequate packing will be repaired at the sender's expense, and it will be the sender's responsibility to make claim with the shipper. Instruments not in warranty should follow the same procedure and ORTEC will provide a quotation.

## **Damage in Transit**

Shipments should be examined immediately upon receipt for evidence of external or concealed damage. The carrier making delivery should be notified immediately of any such damage, since the carrier is normally liable for damage in shipment. Packing materials, waybills, and other such documentation should be preserved in order to establish claims. After such notification to the carrier, please notify ORTEC of the circumstances so that assistance can be provided in making damage claims and in providing replacement equipment, if necessary.

---

Copyright © 2004, Advanced Measurement Technology, Inc. All rights reserved.

\*ORTEC<sup>®</sup> is a registered trademark of Advanced Measurement Technology, Inc. All other trademarks used herein are the property of their respective owners.

## CONTENTS

WARRANTY .....	ii
SAFETY INSTRUCTIONS AND SYMBOLS .....	iv
SAFETY WARNINGS AND CLEANING INSTRUCTIONS .....	v
1. DESCRIPTION .....	1
1.1. GENERAL .....	1
1.2. POLE-ZERO CANCELLATION .....	1
1.3. ACTIVE FILTER .....	2
2. SPECIFICATIONS .....	4
2.1. PERFORMANCE .....	4
2.2. CONTROLS .....	5
2.3. INPUT .....	5
2.4. OUTPUTS .....	5
2.5. ELECTRICAL AND MECHANICAL .....	5
3. INSTALLATION .....	6
3.1. GENERAL .....	6
3.2. CONNECTION TO POWER .....	6
3.3. CONNECTION TO PREAMPLIFIER .....	6
3.4. CONNECTION OF TEST PULSE GENERATOR .....	6
3.5. SHAPING CONSIDERATIONS .....	7
3.6. LINEAR OUTPUT CONNECTIONS AND TERMINATING CONSIDERATIONS .....	7
3.7. SHORTING OR OVERLOADING THE AMPLIFIER OUTPUTS .....	8
3.8. INHIBIT OUTPUT CONNECTION .....	8
3.9. BUSY OUTPUT CONNECTION .....	8
3.10. CRM OUTPUT CONNECTION .....	8
4. OPERATING INSTRUCTIONS .....	8
4.1. INITIAL TESTING AND OBSERVATION OF PULSE WAVEFORMS .....	8
4.2. FRONT PANEL CONTROLS .....	8
4.3. FRONT PANEL CONNECTORS .....	9
4.4. REAR PANEL CONNECTORS .....	10
4.5. STANDARD SETUP PROCEDURE .....	10
4.6. POLE-ZERO ADJUSTMENT .....	10
4.7. BLR THRESHOLD ADJUSTMENT .....	11
4.8. OPERATION WITH SEMICONDUCTOR DETECTORS .....	12
4.9. OPERATION IN SPECTROSCOPY SYSTEMS .....	15
4.10. OTHER EXPERIMENTS .....	16
5. CIRCUIT DESCRIPTION .....	19
6. MAINTENANCE .....	21
6.1. TEST EQUIPMENT REQUIRED .....	21
6.2. PULSER TEST .....	21
6.3. SUGGESTIONS FOR TROUBLESHOOTING .....	23
6.4. FACTORY REPAIR .....	23
6.5. TABULATED TEST POINT VOLTAGES .....	23

## SAFETY INSTRUCTIONS AND SYMBOLS

This manual contains up to three levels of safety instructions that must be observed in order to avoid personal injury and/or damage to equipment or other property. These are:

**DANGER** Indicates a hazard that could result in death or serious bodily harm if the safety instruction is not observed.

**WARNING** Indicates a hazard that could result in bodily harm if the safety instruction is not observed.

**CAUTION** Indicates a hazard that could result in property damage if the safety instruction is not observed.

Please read all safety instructions carefully and make sure you understand them fully before attempting to use this product.

In addition, the following symbol may appear on the product:



**ATTENTION – Refer to Manual**



**DANGER – High Voltage**

Please read all safety instructions carefully and make sure you understand them fully before attempting to use this product.

## SAFETY WARNINGS AND CLEANING INSTRUCTIONS

**DANGER** Opening the cover of this instrument is likely to expose dangerous voltages. Disconnect the instrument from all voltage sources while it is being opened.

**WARNING** Using this instrument in a manner not specified by the manufacturer may impair the protection provided by the instrument.

### Cleaning Instructions

To clean the instrument exterior:

- Unplug the instrument from the ac power supply.
- Remove loose dust on the outside of the instrument with a lint-free cloth.
- Remove remaining dirt with a lint-free cloth dampened in a general-purpose detergent and water solution. Do not use abrasive cleaners.

**CAUTION** To prevent moisture inside of the instrument during external cleaning, use only enough liquid to dampen the cloth or applicator.

- Allow the instrument to dry completely before reconnecting it to the power source.

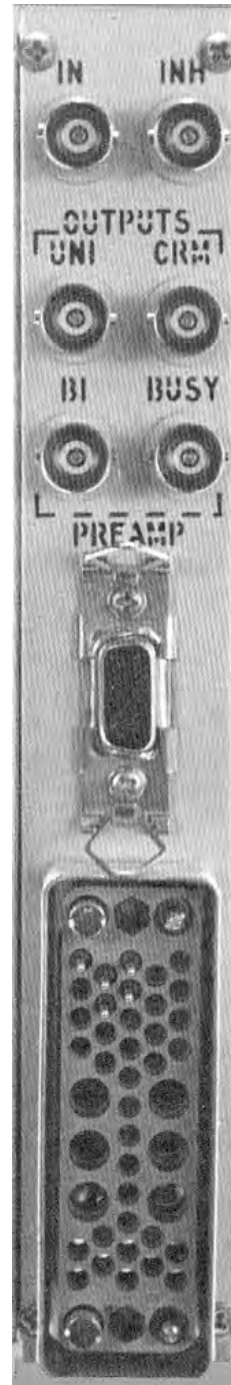

# ORTEC MODEL 572A SPECTROSCOPY PILE-UP AMPLIFIER

## 1. DESCRIPTION

### 1.1. GENERAL

The ORTEC 572A Spectroscopy Amplifier and Pile-Up Rejector is a single-width NIM module with a versatile combination of switch-selectable pulse-shaping and output characteristics. It features extremely low noise, wide gain range, and excellent overload response for universal application in high-resolution spectroscopy. It accepts input pulses of either polarity that originate in germanium or silicon semiconductor detectors, in scintillation counters with either fast or slow scintillators, in proportional counters, in pulsed ionization chambers, in electron multipliers, etc.

The 572A has an input impedance of approximately 500 $\Omega$  and accepts either positive or negative input pulses with rise times <650 ns and fall times >40  $\mu$ s. Six integrate and differentiate time constants are switch-selectable to provide optimum shaping for resolution and count rate. The first differentiation network has variable pole-zero cancellation that can be adjusted to match preamplifiers with decay times >40  $\mu$ s. The pole-zero cancellation drastically reduces the undershoot after the first differentiator and greatly improves overload and count rate characteristics. In addition, the amplifier contains an active filter shaping network that optimizes the signal-to-noise ratio and minimizes the overall resolving time. Both unipolar and bipolar outputs are provided simultaneously on the front and rear panels.

The unipolar output should be used for spectroscopy when dc coupling can be maintained from the 572A to the analyzer. A BLR (baseline restorer) circuit is included in the 572A for improved performance at all count rates. Baseline correction is applied during intervals between input pulses only and a front panel switch selects a discriminator level to identify input pulses. The unipolar output dc level can be adjusted in the range from -100 mV to +100 mV. This output permits the use of the direct-coupled input of the analyzer with a minimum amount of interface problems. The 572A bipolar output may be preferable for spectroscopy when

operating into an ac-coupled system at high counting rates.

Internal pulse pileup (a second pulse arriving before the first pulse has been completed) is sensed internally. The 572A includes an Inhibit output BNC connector on the rear panel that can be used to inhibit measurement of the result of a pulse pileup when it occurs.

The 572A can be used for constant-fraction timing when operated in conjunction with an ORTEC 551 or 552 Timing Single-Channel Analyzer. The ORTEC timing single-channel analyzers feature a minimum of walk as a function of pulse amplitude and incorporate a variable delay time on the output pulse to enable the timing pickoff output to be placed in time coincidence with other signals.

The 572A has complete provisions, including power, for operating any ORTEC solid-state preamplifier. Normally, the preamplifier pulses should have a rise time of 0.25  $\mu$ s or less to properly match the amplifier filter network and a decay time greater than 40  $\mu$ s for proper pole-zero cancellation. The 572A input impedance is 500 $\Omega$ . When long preamplifier cables are used, the cables can be terminated in series at the preamplifier end or in shunt at the amplifier end with the proper resistors. The output impedance is about 0.1 $\Omega$  at the front panel connectors and 93 $\Omega$  at the rear panel connectors. The front panel outputs can be connected to other equipment by a single cable going to all equipment and shunt terminated at the far end of the cabling. If series termination is desired, the rear panel connectors can be used to connect the 572A to other modules. See Section 3 for further information.

### 1.2. POLE-ZERO CANCELLATION

Pole-zero cancellation is a method for eliminating pulse undershoot after the first differentiating network. In an amplifier not using pole-zero cancellation (Fig. 1.1), the exponential tail on the preamplifier output signal (usually 50 to 500  $\mu$ s)

causes an undershoot whose peak amplitude is roughly determined from:

$$\frac{\text{undershoot amplitude}}{\text{differentiated pulse amplitude}} = \frac{\text{differentiation time}}{\text{preamplifier pulse decay time}}$$

For a 1- $\mu$ s differentiation time constant and a 50- $\mu$ s preamplifier pulse decay time, the maximum undershoot is 2% and this decays with a 50- $\mu$ s time constant. Under overload conditions, this undershoot is often sufficiently large to saturate the amplifier during a considerable portion of the undershoot, causing excessive dead time. This effect can be reduced by increasing the preamplifier pulse decay time (which generally reduces the counting rate capabilities of the preamplifier) or compensating for the undershoot by using pole-zero cancellation.

Pole-zero cancellation is accomplished by the network shown in Fig. 1.2. The pole  $[s + (1/T_o)]$  due to the preamplifier pulse decay time is canceled by the zero of the network  $[s + (K/R_2C_1)]$ . In effect, the dc path across the differentiation capacitor adds an attenuated replica of the preamplifier pulse to just cancel the negative undershoot of the differentiating network.

Total preamplifier-amplifier pole-zero cancellation requires that the preamplifier output pulse decay time be a single exponential decay and matched to the pole-zero-cancellation network. The variable pole-zero-cancellation network allows accurate cancellation for all preamplifiers having 40- $\mu$ s or greater decay times. Improper matching of the pole-zero-cancellation network will degrade the overload performance and cause excessive pileup distortion at medium counting rates. Improper matching causes either an under-compensation (undershoot is not eliminated) or an over-compensation (output after the main pulse does not return to the baseline and decays to the baseline with the preamplifier time constant). The pole-zero adjust is accessible from the front panel of the 572A and can easily be adjusted by observing the

baseline with an oscilloscope with a monoenergetic source or pulser having the same decay time as the preamplifier under overload conditions. The adjustment should be made so that the pulse returns to the baseline in the minimum time with no undershoot.

### 1.3. ACTIVE FILTER

When only FET gate current and drain thermal noise are considered, the best signal-to-noise ratio occurs when the two noise contributions are equal for a given input pulse shape. The Gaussian pulse shape (Fig. 1.3) for this condition requires an amplifier with a single RC differentiate and  $n$  equal RC integrates where  $n$  approaches infinity.

The Laplace transform of this transfer function is:

$$G(s) = \frac{s}{s + (1/RC)} \times \frac{1}{[s + (1/RC)]^n} \quad (n \rightarrow \infty)$$

where the first factor is the single differentiate and the second factor is the  $n$  integrates. The 572A active filter approximates this transfer function.

Figure 1.3 illustrates the results of pulse shaping in an amplifier. Of the four pulse shapes shown the cusp would produce minimum noise but is impractical to achieve with normal electronic circuitry and would be difficult to measure with an ADC. The true Gaussian shape deteriorates the signal-to-noise ratio by only about 12% from that of the cusp and produces a signal that is easy to measure, but requires many sections of integration ( $n \rightarrow \infty$ ). With two sections of integration the waveform identified as a Gaussian approximation can be obtained, and this deteriorates the signal-to-noise ratio by about 22%. The ORTEC active filter network in the 572A Amplifier provides the fourth waveform in Fig. 1.3; this waveform has characteristics superior to the Gaussian approximation, yet obtains them with four complex poles. By this method the output pulse shape has a good signal-to-noise ratio, is easy to measure, and yet requires only a practical amount of electronic circuitry to achieve the desired results.



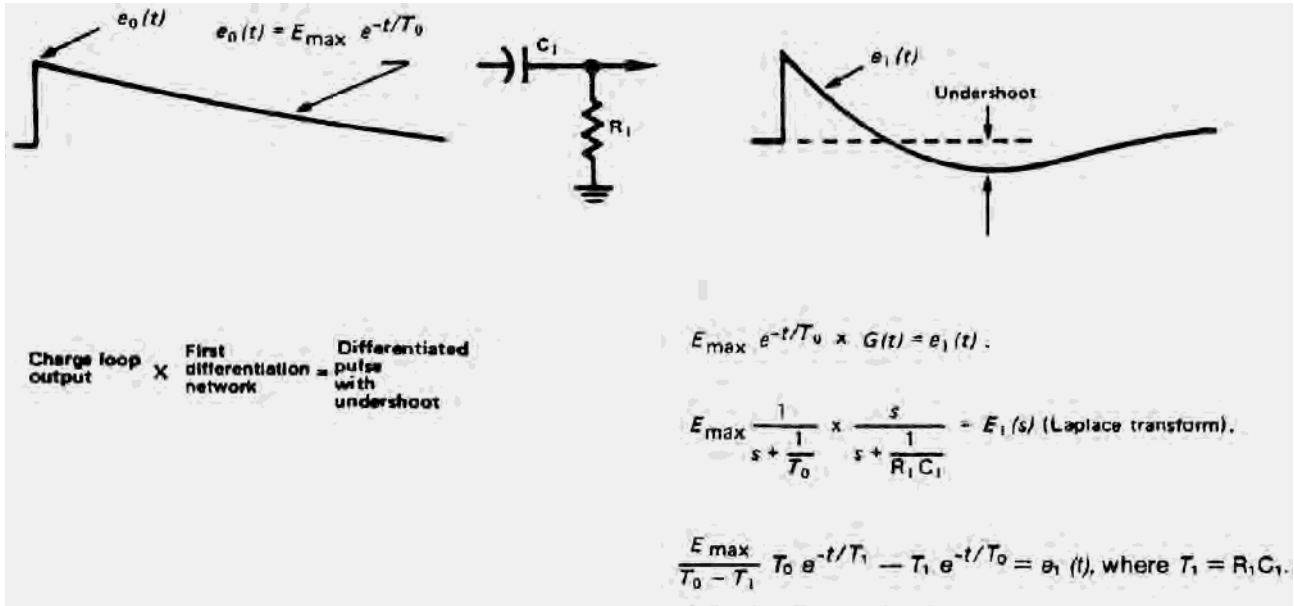

Fig. 1.1. Differentiation in an Amplifier Without Pole-Zero Cancellation.

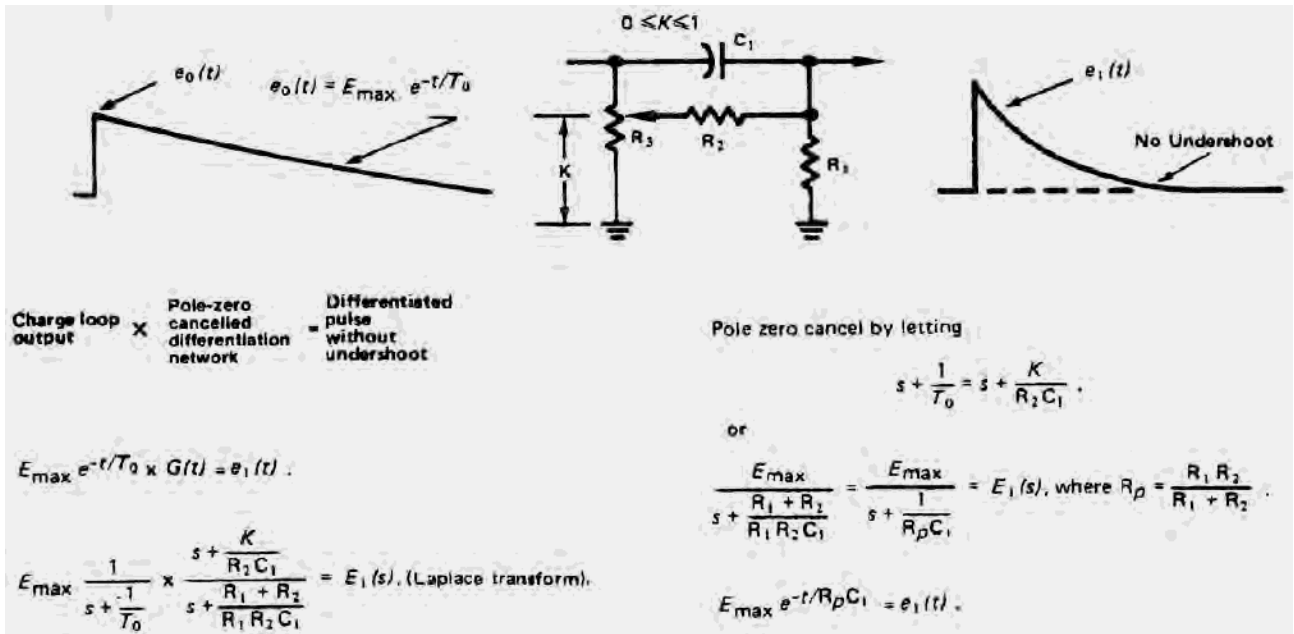

Fig. 1.2. Differentiation in a Pole-Zero Canceled Amplifier.

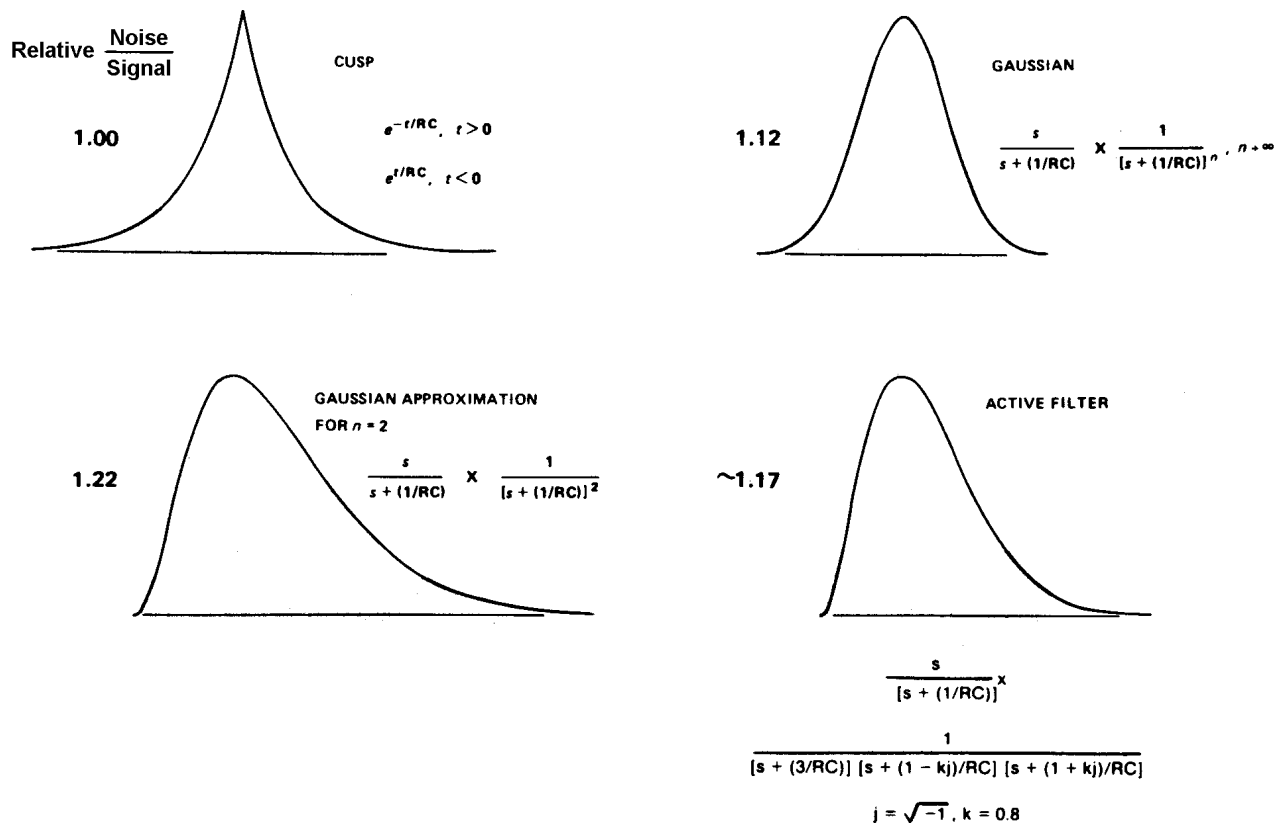

Fig. 1.3. Pulse Shapes for Good Signal-to-Noise Ratios.

## 2. SPECIFICATIONS

### 2.1. PERFORMANCE

**GAIN RANGE** Continuously adjustable from X1 through X1500.

**PULSE SHAPING** Gaussian on all ranges with peaking time equal to  $2.2\tau$  and pulse width at 0.1% level equal to 2.9 times the peaking time.

**INTEGRAL NONLINEARITY**  $<0.05\%$  (0.025% typical) using  $2 \mu\text{s}$  shaping.

**NOISE**  $<8 \mu\text{V}$  referred to the input ( $5 \mu\text{V}$  typical) using  $2 \mu\text{s}$  shaping and gain  $\geq 100$ .

#### TEMPERATURE INSTABILITY

**Gain**  $\leq 0.0075\%/^{\circ}\text{C}$ , 0 to  $50^{\circ}\text{C}$ .

**DC Level**  $<\pm 50 \mu\text{V}/^{\circ}\text{C}$ , 0 to  $50^{\circ}\text{C}$ .

**CROSSOVER WALK**  $\leq \pm 3$  ns for 50:1 dynamic range, including contribution of ORTEC 551 or 552 Constant-Fraction Timing Single-Channel Analyzer using 50% fraction and  $0.5 \mu\text{s}$  shaping.

**COUNT RATE STABILITY** The 1.33 MeV gamma ray peak from a  $^{60}\text{Co}$  source, positioned at 85% of analyzer range, typically shifts  $<0.024\%$ , and its FWHM broadens  $<16\%$  when its incoming count rate changes from 0 to 100000 counts/s using  $2 \mu\text{s}$  shaping. The amplifier will hold the baseline reference up to count rates in excess of 150000 counts/s.

**OVERLOAD RECOVERY** Recovers to within 2% of rated output from X300 overload in 2.5 nonoverloaded unipolar pulse widths, using maximum gain; same recovery from X1000 overload for bipolar pulses.

## 2.2. CONTROLS

**GAIN** Ten-turn precision potentiometer for continuously variable direct-reading gain factor of X0.5 to X1.5.

**COARSE GAIN** Six-position selector switch selects feedback resistors for gain factors of 20, 50, 100, 200, 500, and 1 K.

**INPUT ATTENUATOR** Jumper on printed circuit board selects an input attenuation factor of 1 or 10 (gain factor of X1 or X0.1).

**POS/NEG** Toggle switch selects input circuit for either polarity of input pulses from the preamplifier.

**SHAPING TIME** Six-position switch selects time constant for active filter network pulse shaping; selections are 0.5, 1, 2, 3, 6, and 10  $\mu$ s.

**PZ ADJ** Potentiometer to adjust pole-zero cancellation for decay times from 40  $\mu$ s to  $\infty$ . Factory preset at 50  $\mu$ s to match normal characteristics of ORTEC preamplifiers.

**BLR** Toggle switch selects a source for the gated baseline restorer discriminator threshold level from one of three positions.

- **Auto** The BLR threshold is automatically set to an optimum level as a function of the signal noise level by an internal circuit. This allows easy setup and very good performance under most conditions.
- **PZ Adj** The BLR threshold is determined by the threshold potentiometer. The BLR time constant is greatly increased to facilitate PZ adjustment. This position may give the lowest noise for conditions of low count rate and/or longer shaping times.
- **Threshold** The BLR threshold is set manually by the threshold potentiometer. Range is 0 to 300 mV referred to the positive output signal. The BLR time constant is the same as for the Auto switch setting.

**DC** Screwdriver potentiometer adjusts the unipolar output baseline dc level; range, +100 mV to -100 mV.

## 2.3. INPUT

**INPUT** Type BNC front and rear panel connectors accept either positive or negative pulses with rise times in the range from 10 to 650 ns and decay times from 40 to 2000  $\mu$ s;  $Z_{in} \sim 500\Omega$ , dc coupled; linear maximum, 1 V (10V with attenuator jumper set at X0.1); absolute maximum, 20 V.

## 2.4. OUTPUTS

**UNI** Unipolar front panel BNC with  $Z_{in} < 1\Omega$  and rear panel BNC with  $Z_{in} = 93\Omega$ . Short-circuit proof; prompt; full-scale linear range 0 to +10 V; active filter shaped and dc restored; dc level adjustable to  $\pm 100$  mV.

**Bi** Bipolar front panel BNC with  $Z_{in} < 10\Omega$  and rear panel BNC with  $Z_{in} = 93\Omega$ . Short-circuit proof; prompt output with positive lobe leading and linear range of  $\pm 10$ V; active filter shaped.

**BUSY** Rear panel BNC with  $Z_{in} < 10\Omega$  provides a +5 V logic pulse for the duration that the input pulse exceeds the baseline restorer discriminator level. Connect to the ORTEC MCA Busy input for dead time correction.

**INH** Inhibit rear panel BNC with  $Z_{in} < 10\Omega$  provides a nominal +5 V logic signal when an internal pulse pileup occurs: width  $\sim 6\tau$  in coincidence with the pileup; to be used for an MCA anticoincidence input to prevent storage of pileup data in the spectrum.

**CRM** Count Rate meter rear panel BNC furnishes a nominal +5 V logic signal for every linear input pulse; width, 300 ns; to be used as an input to a ratemeter or counter.

**PREAMP POWER** Rear panel standard ORTEC power connector; Amphenol 17-10090; mates with captive and non-captive power cords on all standard ORTEC preamplifiers.

## 2.5. ELECTRICAL AND MECHANICAL

**POWER REQUIRED (not including any load on the Preamp Power connector)**

+24 V, 100 mA; -24 V, 105 mA;  
+12 V, 85 mA; -12 V, 50 mA.

**FRONT PANEL DIMENSIONS** NIM-standard single-width module (1.35 by 8.714 in.) per TID-20893.

### 3. INSTALLATION

#### 3.1. GENERAL

The 572A operates on power that must be furnished from a NIM-standard bin and power supply such as the ORTEC 4001/4002 Series. The bin and power supply is designed for relay rack mounting. If the equipment is to be rack mounted, be sure that there is adequate ventilation to prevent any localized heating of the components that are used in the 572A. The temperature of equipment mounted in racks can easily exceed the maximum limit of 50 °C unless precautions are taken.

#### 3.2. CONNECTION TO POWER

The 572A contains no internal power supply and must obtain the necessary dc operating power from the bin and power supply in which it is installed for operation. Always turn off power for the power supply before inserting or removing any modules. After all modules have been installed in the bin and any preamplifiers have also been connected to the Preamp Power connectors on the amplifiers, check the dc voltage levels from the power supply to see that they are not overloaded. The ORTEC 4001/4002 Series Bins and Power Supplies have convenient test points on the power supply control panel to permit monitoring these dc levels. If any one or more of the dc levels indicates an overload, some of the modules will need to be moved to another bin to achieve operation.

#### 3.3. CONNECTION TO PREAMPLIFIER

The preamplifier output signal is connected to the 572A through the appropriate Input BNC connector on the front or rear panel. The input impedance is about 500 $\Omega$  and is dc-coupled to ground; therefore the preamplifier output must be either ac-coupled or have approximately zero dc voltage under no-signal conditions.

The 572A incorporates pole-zero cancellation in order to enhance the overload and count rate characteristics of the amplifier. This technique requires matching the network to the preamplifier decay time constant in order to achieve perfect compensation. The pole-zero adjustment should be set each time the preamplifier or the shaping time constant of the amplifier is changed. For details of the pole-zero adjustment see Section 4.6. An alternate method is accomplished easily by using a monoenergetic source and observing the amplifier

baseline with an oscilloscope after each pulse under approximately X2 overload conditions. Adjustment should be made so that the pulse returns to the baseline in a minimum amount of time with no undershoot.

Preamplifier power at +24 V, -24 V, +12 V, and -12 V is available through the Preamp Power connector on the rear panel. When the preamplifier is connected, its power requirements are obtained from the same bin and power supply as is used for the amplifier, and this increases the dc loading on each voltage level over and above the requirements for the 572A at the module position in the bin.

When the 572A is used with a remotely located preamplifier (i.e., preamplifier-to-amplifier connection through 25 ft or more of coaxial cable), be careful to ensure that the characteristic impedance of the transmission line from the preamplifier output to the 572A input is matched. Since the input impedance of the 572A is about 500 $\Omega$ , sending-end termination will normally be preferred; the transmission line should be series-terminated at the preamplifier output. All ORTEC preamplifiers contain series terminations that are either 93 $\Omega$  or variable; coaxial cable type RG-62/U or RG-71/U is recommended.

#### 3.4. CONNECTION OF TEST PULSE GENERATOR

**THROUGH A PREAMPLIFIER** The satisfactory connection of a test pulse generator such as the ORTEC 419 Precision Pulse Generator or equivalent depends primarily on two considerations; the preamplifier must be properly connected to the 572A as discussed in Section 3.3, and the proper input signal simulation must be applied to the preamplifier. To ensure proper input signal simulation, refer to the instruction manual for the particular preamplifier being used.

**DIRECTLY INTO THE 572A** Since the input of the 572A has 500 $\Omega$  of input impedance, the test pulse generator will normally have to be terminated at the amplifier input with an additional shunt resistor. In addition, if the test pulse generator has a dc offset, a large series isolating capacitor is also required since the 572A input is dc coupled. The ORTEC test pulse generators are designed for

direct connection. When any one of these units is used, it should be terminated with a  $100\Omega$  terminator at the amplifier input or be used with at least one of the output attenuators set at In. (The small error due to the finite input impedance of the amplifier can normally be neglected.)

**SPECIAL CONSIDERATIONS FOR POLE-ZERO CANCELLATION** When a tail pulser is connected directly to the amplifier input, the PZ Adj should be adjusted if overload tests are to be made (other tests are not affected). See Section 4.6 for the pole-zero adjustment. If a preamplifier is used and a tail pulser is connected to the preamplifier test input, similar precautions are necessary. In this case the effect of the pulser decay must be removed; i.e., a step input should be simulated.

### 3.5. SHAPING CONSIDERATIONS

The shaping time constant on the 572A is switch-selectable in steps of 0.5, 1, 2, 3, 6, and 10  $\mu\text{s}$ . The choice of the proper shaping time constant is generally a compromise between operating at a shorter time constant for accommodation of high counting rates and operating with a longer time constant for a better signal-to-noise ratio. For scintillation counters the energy resolution depends largely on the scintillator and photomultiplier, and therefore a shaping time constant of about four times the decay-time constant of the scintillator is a reasonable choice (for NaI, a 1- $\mu\text{s}$  shaping time constant is about optimum). For gas proportional counters the collection time is normally in the 0.5 to 5  $\mu\text{s}$  range and a 2  $\mu\text{s}$  or greater time constant selection will generally give optimum resolution. For surface barrier semiconductor detectors, a 0.5 to 2  $\mu\text{s}$  resolving time will generally provide optimum resolution. Shaping time for Ge(Li) detectors will vary from 1 to 6  $\mu\text{s}$ , depending on the size, configuration, and collection time of the specific detector and preamplifier. When a charge-sensitive preamplifier is used, the optimum shaping time constant to minimize the noise of a system can be determined by measuring the output noise of the system and dividing it by the system gain. Since the 572A has almost constant gain for all shaping modes, the optimum shaping can be determined by measuring the output noise of the 572A with a voltmeter as each shaping time constant is selected.

The 572A provides both unipolar and bipolar outputs. The unipolar output pulses should be used

in applications where the best signal-to-noise ratio (resolution) is most important, such as high-resolution spectroscopy using semiconductor detectors. Use of the unipolar output with baseline restoration will also give excellent resolution at high counting rates. The bipolar output should be used in high count rate systems when the analyzer system is ac-coupled and noise, or resolution, is a secondary consideration.

### 3.6. LINEAR OUTPUT CONNECTIONS AND TERMINATING CONSIDERATIONS

Since the 572A unipolar output is normally used for spectroscopy the 572A is designed with a great amount of flexibility in order for the pulse to be interfaced with an analyzer. A gated baseline restorer (BLR) circuit is included in this output for improved performance at all count rates. A switch on the front panel permits the threshold for the restorer gate to be determined automatically, according to the input noise level, or manually, with a screwdriver adjustment. The switch also has a center PZ Adj setting that can be used to eliminate the BLR effect when making pole-zero adjustments.

The unipolar output dc level can be adjusted from -0.1 to +0.1 V to set the zero intercept on the analyzer when direct coupling is used. The bipolar output, with a 0 to 10 V range, can be used for crossover timing or may be preferred for spectroscopy when operating into ac-coupled systems at high counting rates. Typical system block diagrams for a variety of experiments are described in Section 4.

Three general methods of termination are used. The simplest of these is shunt termination at the receiving end of the cable. A second method is series termination at the sending end. The third is a combination of series and shunt termination, where the cable impedance is matched both in series at the sending end and in shunt at the receiving end. The combination is most effective, but this reduces the amount of signal strength at the receiving end to 50% of that which is available in the sending instrument.

To use shunt termination at the receiving end of the cable, connect the  $<1\Omega$  output of the 572A (on the front panel) through  $93\Omega$  cable to the input of the receiving instrument. Then use a BNC tee connector to attach both the interconnecting cable and a  $100\Omega$  terminator at the input connector of the

receiving instrument. Since the input impedance of the receiving instrument is normally  $1000\Omega$  or more, the effective instrument input impedance with the  $100\Omega$  terminator will be of the order of  $93\Omega$  and this matches the cable impedance correctly.

For series termination use the  $93\Omega$  output of the 572A for the cable connection. Use  $93\Omega$  cable to interconnect this into the input of the receiving instrument. The  $1000\Omega$  (or more) normal input impedance at the input connector represents an essentially open circuit, and the series impedance in the 572A now provides the proper termination for the cable.

For the combination of series and shunt termination, use the  $93\Omega$  output on the rear panel of the 572A and use  $93\Omega$  cable. At the input for the receiving instrument use a BNC tee to attach both the signal cable and a  $100\Omega$  resistive terminator. Note that the signal span at the receiving end of this type of circuit will always be reduced to 50% of the signal span furnished by the sending instrument.

For customer convenience, ORTEC stocks the proper terminators and BNC tees, or they can be ordered from a variety of commercial sources.

### 3.7. SHORTING OR OVERLOADING THE AMPLIFIER OUTPUTS

All outputs of the 572A are dc-coupled with an output impedance of about  $0.1\Omega$  for the front panel connectors and  $93\Omega$  for the rear panel connectors. If the output is shorted with a direct short circuit the output stage will limit the peak current of the output so that the amplifier will not be harmed. When the amplifier is terminated with  $100\Omega$ , the maximum

rate allowed to maintain the linear output is  $[200000 \text{ cps}/\tau(\mu\text{s})] \times [10/V_o(\text{V})]$ .

### 3.8. INHIBIT OUTPUT CONNECTION

The Inhibit output on the rear panel is intended for application at the anticoincidence input of the Analyzer. An output pulse is generated through this connector when a pulse pileup is sensed in the 572A, and the pulse can then be used to prevent the Analyzer from measuring and storing a false amplitude. The signal is dc-coupled and rises from 0 to about +5 V for a time equal to  $6\tau$ , starting when a pileup occurs.

### 3.9. BUSY OUTPUT CONNECTION

The signal through the rear panel Busy output connector rises from 0 to about +5 V at the onset of each linear input Pulse. Its width is equal to the time the input pulse amplitude exceeds the BLR discriminator level, and is extended automatically by the generation of an Inhibit output signal. It can be used to provide MCA live-time correction, to control the generation of input pulses, to observe normal operation with an oscilloscope, or for any of a variety of other applications. Its use is optional and no termination is required if the output is not being used.

### 3.10. CRM OUTPUT CONNECTION

One NIM-standard positive logic pulse is generated to correspond to each linear input pulse into the 572A. The pulses are available through the CRM (Count Rate Meter) output BNC on the rear panel and are intended for use in a count rate meter or counter to monitor the true input count rate into the amplifier. Its use is optional and no termination is required if the output is not being used.

## 4. OPERATING INSTRUCTIONS

### 4.1. INITIAL TESTING AND OBSERVATION OF PULSE WAVEFORMS

Refer to Section 6 for information on testing performance and observing waveforms at front panel test points. Figure 4.1 shows some typical unipolar and bipolar output waveforms.

### 4.2. FRONT PANEL CONTROLS

**GAIN** A coarse Gain switch and a Gain 10-turn locking precision potentiometer select and precisely adjust the gain factor for the amplification in the 572A. Switch settings are X20, 50, 100, 200, 500, and 1000. Continuous fine gain range is from X0.5 to X1.5, using markings of 500 through 1500 dial divisions. An internal jumper setting provides one additional gain factor selection of either X1.0 or X0.1. Collectively the range of gain can be set at

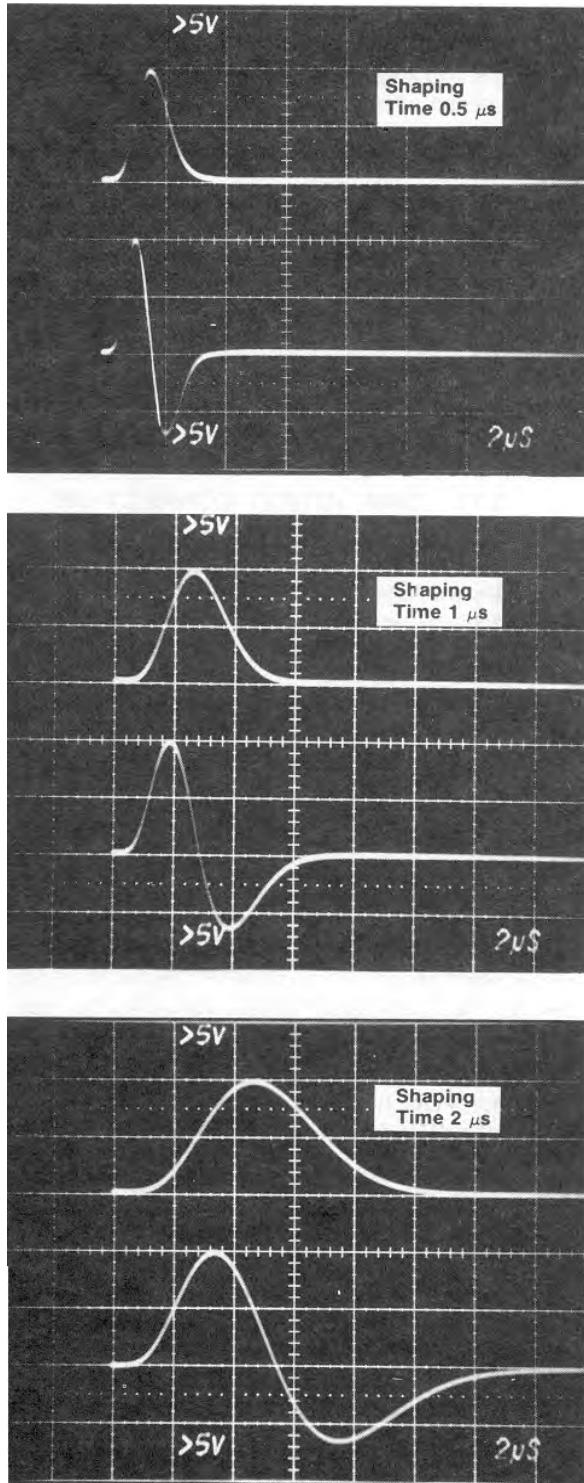

Fig. 4.1. Typical Effects of Shaping-Time Selection on Output Waveforms.

any level from X1.0 through X1500, using all three of these controls.

**POS/NEG** A toggle switch selects an input circuit that accepts either polarity of pulses from the preamplifier.

**PZ ADJ** A screwdriver control to set the pole-zero cancellation to match the preamplifier pulse decay characteristics. The range is from 40  $\mu$ s to infinity.

**DC** A screwdriver control adjusts the dc baseline level of the unipolar output in the range of -0.1 V to +0.1 V.

**SHAPING** A 6-position switch selects equal integrate and differentiate time constants to shape the input pulses. Settings are 0.5, 1, 2, 3, 6, and 10  $\mu$ s.

**BLR** A 3-position toggle switch controls the operation of the internal baseline restorer (BLR) circuit. The center setting of the switch is effectively Off, and this permits adjustment of the PZ Adj control without interference from the BLR circuit. The Auto setting of the switch selects a circuit that regulates the threshold of the BLR gate according to the output noise level. The Threshold setting permits manual control of the BLR gate threshold using the screwdriver control immediately below the toggle switch.

### 4.3. FRONT PANEL CONNECTORS

**INPUT** Accepts input pulses to be shaped and/or amplified by the 572A. Compatible characteristics; positive or negative with rise time from 10 to 650 ns; decay time greater than 40  $\mu$ s for proper pole-zero cancellation; input linear amplitude range 0 to 10 V, with a maximum limit of  $\pm 20$  V. Input impedance is approximately 500 $\Omega$ .

**UNI** Provides a unipolar positive output with characteristics that are related to input peak amplitude, gain, shaping time constants, pole-zero cancellation, and baseline stabilization. The dc baseline level is adjustable for offset to  $\pm 0.1$  V. Output impedance through this connector is about 0.1  $\Omega$ , dc coupled. Linear range 0 to +10V.

**BI** Provides a bipolar pulse with positive lobe leading and with characteristics that are related to input peak amplitude, gain, and shaping time constants. Timing is prompt with respect to the input. Crossover walk of this output is less than 3 ns (see Specifications). Output impedance through

this connector is about  $0.1 \Omega$ . Linear range of 0 to  $\pm 10V$ .

#### 4.4. REAR PANEL CONNECTORS

**IN** Bridged with front panel input connector for optional use as an alternate input connection location.

**INH** Provides an output signal to identify a pulse pileup in the 572A. Connect it to the anticoincidence input of the multichannel analyzer to inhibit measurement and storage of false amplitudes.

**UNI** Provides a unipolar positive output with the same characteristics as described for the front panel Uni connector; the output impedance through this connector is  $93\Omega$ .

**BI** Provides a bipolar output with the same characteristics as described for the front panel BI connector; the output impedance through this connector is  $93\Omega$ .

**CRM** Provides a NIM-standard ( $\approx +5 V$ ) slow positive logic output for each linear input pulse. The output can be connected into a ratemeter or counter to monitor the true input count rate for the amplifier.

**BUSY** Provides a signal that rises to approximately +5V for the time that the input pulse amplitude exceeds the BLR discriminator level, which can be controlled manually or automatically. The output can be used to correct for live time in the ORTEC MCA by connecting it to the MCA Busy input.

**PREAMP** Provides power connections from the bin and power supply to the ORTEC preamplifier. The dc levels include +24 V, -24 V, +12 V, and -12 V.

#### 4.5. STANDARD SETUP PROCEDURE

a. Connect the detector, preamplifier, high voltage power supply, and amplifier into a basic system and connect the amplifier unipolar output to an oscilloscope. Connect the preamplifier power cable to the Preamp power connector on the rear panel of the 572A. Turn on power in the Bin and Power Supply and allow the electronics of the system to warm up and stabilize.

b. Set the 572A controls initially as follows:

Shaping	2 $\mu s$
Coarse Gain	50
Gain	1.000
Internal Jumper	X1.0
BLR	PZ Adj
Thresh	Fully clockwise
Pos/Neg	Match preamplifier output polarity

c. Use a  $^{60}\text{Co}$  calibration source, set about 25 cm from the active face of the detector. The unipolar output pulse from the 572A should be about 8 to 10 V, using a preamplifier with a conversion gain of 170 mV/MeV.

d. Readjust the Gain control so that the higher peak from the  $^{60}\text{Co}$  source (1.33 MeV) provides an amplifier output at about 9 V.

#### 4.6. POLE-ZERO ADJUSTMENT

The pole-zero adjustment is extremely critical for good performance at high count rates. This adjustment should be checked carefully for the best possible results.

##### USING Ge(Li) SYSTEM AND $^{60}\text{Co}$

a. Adjust the radiation source count rate between 2 kHz and 10 kHz.

b. Observe the unipolar output with an oscilloscope. Adjust the PZ Adj control so that the trailing edge of the pulses returns to the baseline without overshoot or undershoot (see Fig. 4.2).

The oscilloscope used must be dc-coupled and must not contribute distortion in the observed waveforms. Oscilloscopes such as Tektronix 453, 454, 465, and 475 will overload for a 10-V signal when the vertical sensitivity is less than 100 mV/cm. To prevent overloading the oscilloscope, use the clamp circuit shown in Fig. 4.3.

##### USING SQUARE WAVE THROUGH PREAMPLIFIER TEST INPUT

A more precise pole-zero adjustment in the 572A can be obtained by using a square wave signal as the input to the preamplifier. Many oscilloscopes include a calibration output on the front panel and this is a good source of square wave signals at a frequency of about 1 kHz. The amplifier differentiates the signal from the preamplifier so



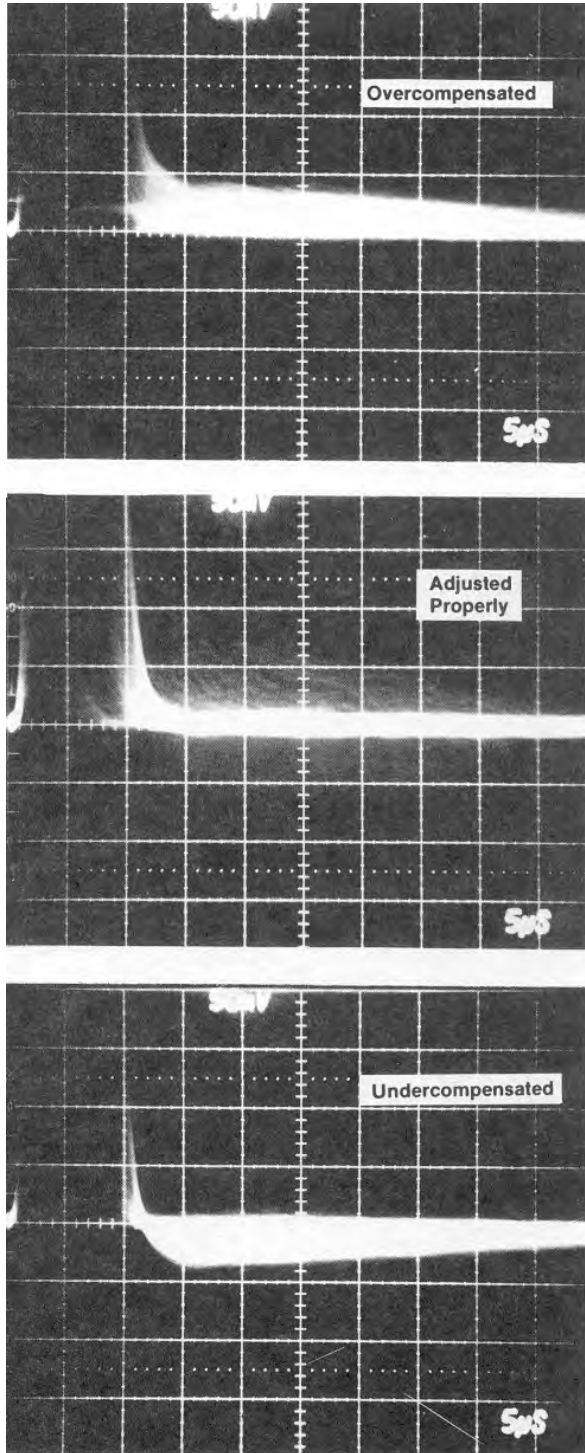

Fig. 4.2. Typical Waveforms Illustrating Pole-Zero Adjustment Effects; Oscilloscope Trigger, 572A Busy Output;  $^{60}\text{Co}$  Source with 1.33-MeV Peak Adjusted  $\sim 9$  V; Count Rate, 3 kHz; Shaping Time Constant, 2  $\mu\text{s}$ .

that it generates output signals of alternate polarities on the leading and trailing edges of the square wave input signal, and these can be

compared as shown in Fig. 4.4 to achieve excellent pole-zero cancellation.

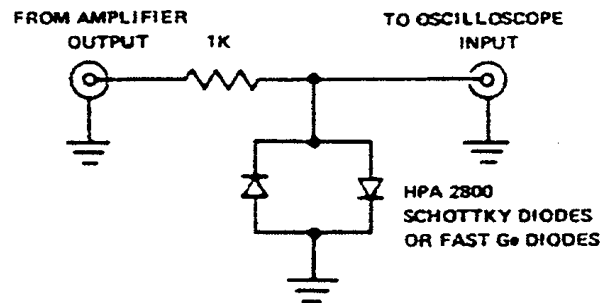

Fig. 4.3. A Clamp Circuit that Can Be Used to Prevent Overloading the Oscilloscope Input.

Use the following procedure:

- a. Remove all radioactive sources from the vicinity of the detector. Set up the system as for normal operation, including detector bias.
- b. Set the 572A controls as for normal operation; this includes gain, shaping, and input polarity.
- c. Connect the source of 1-kHz square waves through an attenuator to the Test input of the preamplifier. Adjust the attenuator so that the 572A output amplitude is about 9 V.
- d. Observe the unipolar output of the 572A with an oscilloscope, triggered from the 572A Busy output. Adjust the PZ Adj control for proper response according to Fig. 4.4. Use the clamp circuit of Fig. 4.3 to prevent overloading the oscilloscope input.

Figure 4.4A shows the amplifier output as a series of alternate positive and negative Gaussian pulses. In the other three pictures of this figure the oscilloscope was triggered to show both positive and negative pulses simultaneously. These pictures show more detail to aid in proper adjustment.

#### 4.7. BLR THRESHOLD ADJUSTMENT

After the amplifier gain and shaping have been selected and the PZ Adj control has been set to operate properly for the particular shaping time, the BLR Thresh control can be used to establish the correct discriminator threshold for the baseline restorer circuit. Normally, the toggle switch can be set at Auto and the threshold level will be set automatically just above the noise level. If desired,

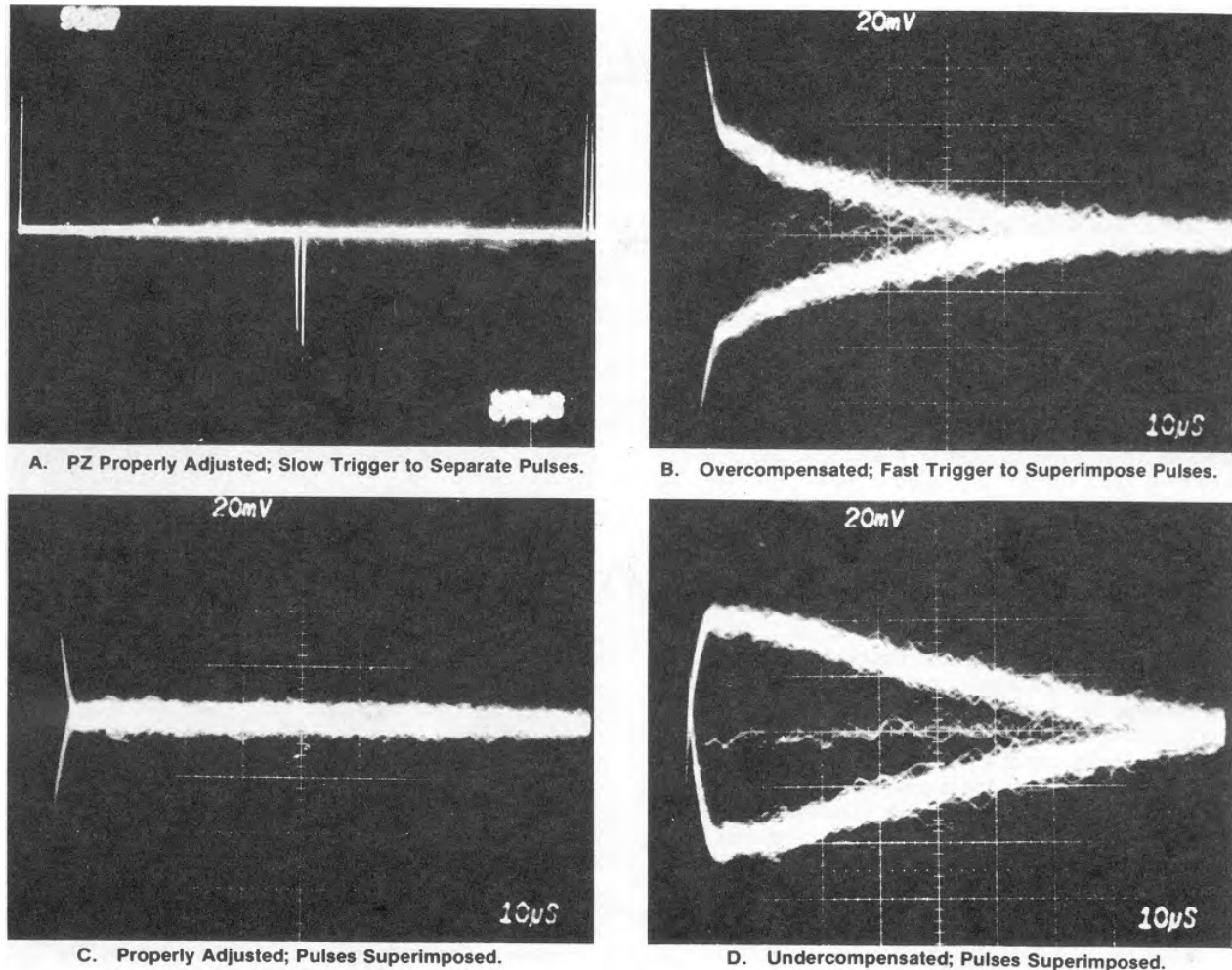

Fig. 4.4. Pole-Zero Adjustment Using a Square Wave Input to the Preamplifier.

the switch can be set at Threshold and the manual control just below the switch can then be used to select the level manually as follows:

- a. Remove all radioactive sources from the vicinity of the detector. Set up the system as for normal operation, including detector bias.
- b. Set the BLR switch at Threshold and turn the control fully clockwise, for 300 mV.
- c. Observe the unipolar output on the 100mV/cm scale of the oscilloscope, using 5  $\mu$ s/cm horizontal deflection. Trigger the oscilloscope with the Busy output from the 572A.
- d. Reduce the control setting until the baseline discriminator begins to trigger on noise; this corresponds to about 200 counts/s from the Busy

output. Adjust the trigger level according to the information in Fig. 4.5.

If a ratemeter or counter-timer is available, it can be connected to the Busy output and the threshold level can then be adjusted for about 200 counts/s.

#### 4.8. OPERATION WITH SEMICONDUCTOR DETECTORS

**CALIBRATION OF TEST PULSER** An ORTEC 419 Precision Pulse Generator, or equivalent, is easily calibrated so that the maximum pulse height dial reading (1000 divisions) is equivalent to a 10-MeV loss in a silicon radiation detector. The procedure is as follows:

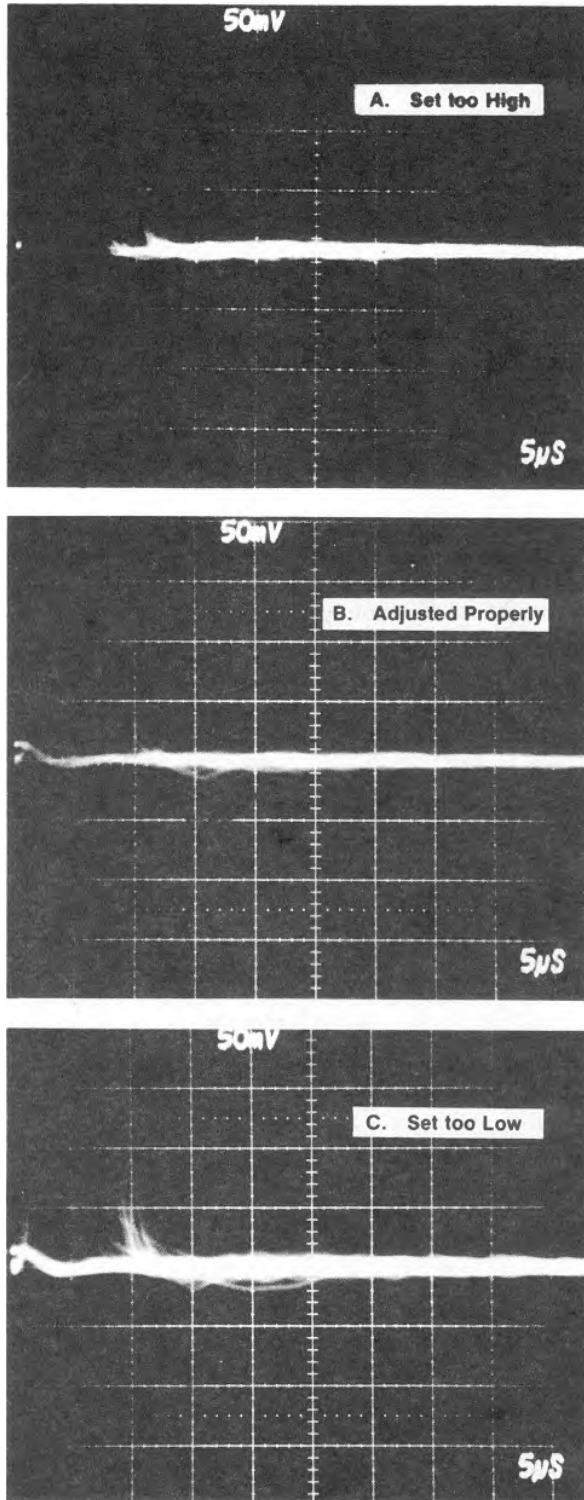

Fig. 4.5. BLR Threshold Variable Control Settings.

a. Connect the detector to be used to the spectrometer system, i.e., preamplifier, main amplifier, and biased amplifier.

b. Allow excitation from a source of known energy (for example, alpha particles) to fall on the detector.

c. Adjust the amplifier gain and the bias level of the biased amplifier to give a suitable output pulse.

d. Set the pulser Pulse Height control at the energy of the alpha particles striking the detector (for example, set the dial at 547 divisions for a 5.47-MeV alpha particle energy).

e. Turn on the pulser and use its Normalize control and attenuators to set the output due to the pulser for the same pulse height as the pulse obtained in step c. Lock the Normalize control and do not move it again until recalibration is required.

The pulser is now calibrated; the Pulse Height dial read directly in MeV if the number of dial divisions is divided by 100.

#### AMPLIFIER NOISE AND RESOLUTION MEASUREMENTS

As shown in Fig. 4.6, a preamplifier, amplifier, pulse generator, oscilloscope, and wide-band rms voltmeter such as the Hewlett-Packard 3400A are required for this measurement. Connect a suitable capacitor to the input to simulate the detector capacitance desired. To obtain the resolution spread due to amplifier noise:

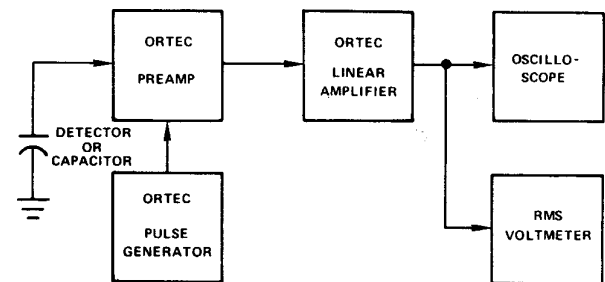

Fig. 4.6. System for Measuring Amplifier and Detector Noise Resolution.

a. Measure the rms noise voltage ( $E_{rms}$ ) at the amplifier output.

b. Turn on the 419 Precision Pulse Generator and adjust the pulser output to any convenient readable voltage,  $E_0$ , as determined by the oscilloscope.

The full width at half maximum (FWHM) resolution spread due to amplifier noise is then:

$$N(FWHM) = \frac{2.35 E_{rms} E_{dial}}{E_o}$$

where  $E_{dial}$  is the pulser dial reading in MeV and 2.35 is the factor for rms to FWHM. For average-responding voltmeters such as the Hewlett-Packard 400D, the measured noise must be multiplied by 1.13 to calculate the rms noise.

The resolution spread will depend on the total input capacitance, since the capacitance degrades the signal-to-noise ratio much faster than the noise.

#### DETECTOR NOISE-RESOLUTION MEASUREMENTS

The measurement just described can be made with a biased detector instead of the external capacitor that would be used to simulate detector capacitance. The resolution spread will be larger because the detector contributes both noise and capacitance to the input. The detector noise-resolution spread can be isolated from the amplifier noise spread if the detector capacity is known, since:

$$(N_{det})^2 + (N_{amp})^2 = (N_{total})^2$$

where  $N_{total}$  is the total resolution spread and  $N_{amp}$  is the amplifier resolution spread when the detector is replaced by its equivalent capacitance.

The detector noise tends to increase with bias voltage, but the detector capacitance decreases, thus reducing the resolution spread. The overall resolution spread will depend upon which effect is dominant. Figure 4.7 shows curves of typical noise-resolution spread versus bias voltage, using data from several ORTEC silicon surface-barrier semiconductor radiation detectors.

#### AMPLIFIER NOISE-RESOLUTION MEASUREMENTS USING MCA

Probably the most convenient method of making resolution measurements is with a pulse height analyzer as shown by the setup illustrated in Fig. 4.8.

The amplifier noise-resolution spread can be measured directly with a pulse height analyzer and the mercury pulser as follows:

a. Select the energy of interest with an ORTEC 419 Precision Pulse Generator. Set the amplifier gain

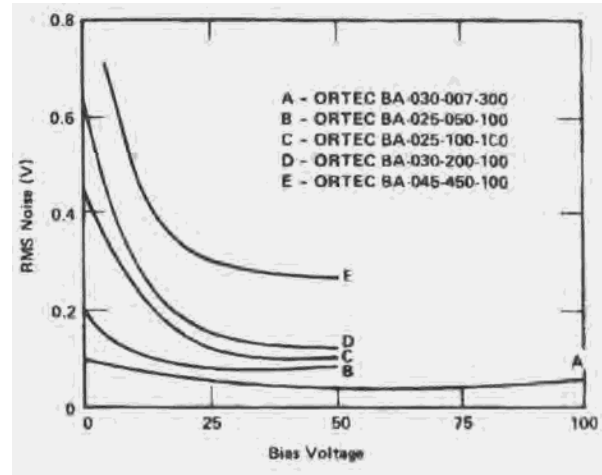

Fig. 4.7. Noise as a Function of Bias Voltage.

so that the energy is in a convenient channel of the analyzer.

b. Calibrate the analyzer in keV per channel, using the pulser; full scale on the pulser dial is 10 MeV when calibrated as described above.

c. Obtain the amplifier noise-resolution spread by measuring the FWHM of the pulser peak in the spectrum.

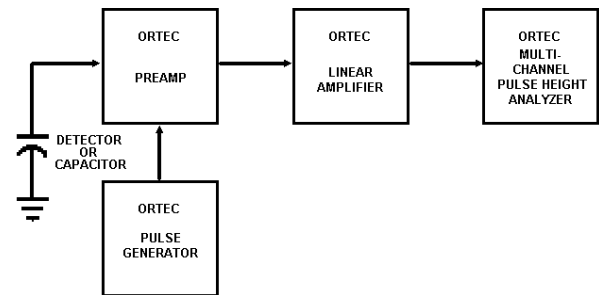

Fig. 4.8. System for Measuring Resolution with a Pulse Height Analyzer.

The detector noise-resolution spread for a given detector bias can be determined in the same manner by connecting a detector to the preamplifier input. The amplifier noise-resolution spread must be subtracted as described in "Detector Noise-Resolution Measurements." The detector noise will vary with detector size and bias conditions and possibly with ambient conditions.

**CURRENT-VOLTAGE MEASUREMENTS FOR Si and Ge DETECTORS** The amplifier system is not directly involved in semiconductor detector current-voltage measurements, but the amplifier serves to permit noise monitoring during the setup. The detector noise measurement is a more sensitive method than a current measurement of determining the maximum detector voltage that should be used because the noise increases more rapidly than the reverse current at the onset of detector breakdown. Make this measurement in the absence of a source.

Figure 4.9 shows the setup required for current-voltage measurements. An ORTEC 428 Bias Supply is used as the voltage source. Bias voltage should be applied slowly and reduced when noise increases rapidly as a function of applied bias. Figure 4.10 shows several typical current-voltage curves for ORTEC silicon surface-barrier detectors.

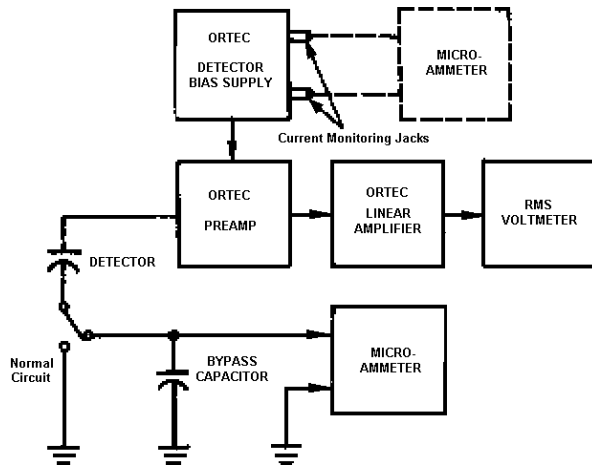

Fig. 4.9. System for Detector Current and Voltage Measurements.

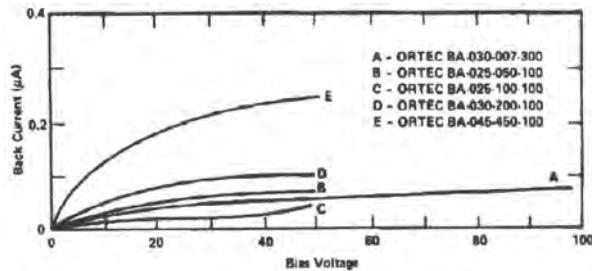

Fig. 4.10. Silicon Detector Back Current vs Bias Voltage.

When it is possible to float the microammeter at the detector bias voltage, the method of detector current measurement shown by the dashed lines in

Fig. 4.9 is preferable. The detector is grounded as in normal operation and the microammeter is connected to the current monitoring jack on the 428 Detector Bias Supply.

#### 4.9. OPERATION IN SPECTROSCOPY SYSTEMS

**HIGH-RESOLUTION ALPHA-PARTICLE SPECTROSCOPY SYSTEM** The block diagram of a high-resolution Spectroscopy system for measuring natural alpha particle radiation is shown in Fig. 4.11. Alpha-particle resolution is obtained in the following manner:

- Use appropriate amplifier gain. Accumulate the alpha peak in the MCA.
- Slowly increase the amplifier gain until the alpha peak is spread over 5 to 10 channels.
- Calibrate the analyzer in keV per channel using the pulser and the known energy of the alpha peak (see "Calibration of Test Pulser") or two known energy alpha peaks.

- Calculate the resolution by measuring the number of channels at the FWHM level in the peak and converting this to keV.

**HIGH-RESOLUTION GAMMA SPECTROSCOPY SYSTEM** A high-resolution gamma spectroscopy system block diagram is shown in Fig. 4.12. When germanium detectors that are cooled by a liquid nitrogen cryostat are used, it is possible to obtain resolutions from about 1 keV FWHM up (depending on the energy of the incident radiation and the size and quality of the detector). Reasonable care is required to obtain such results. So me guidelines for obtaining optimum resolution are:

- Keep interconnection capacities between the detector and preamplifier to an absolute minimum (no long cables).
- Keep humidity low near the detector-preamplifier junction.
- Operate the amplifier with the shaping time that provides the best signal-to-noise ratio.

- Operate at the highest allowable detector bias to keep the input capacity low.

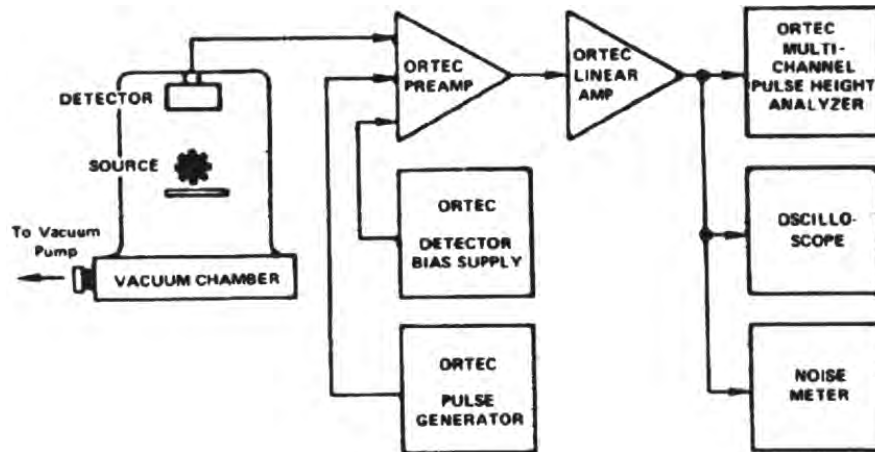

Fig. 4.11. System for High-Resolution Alpha-Particle Spectroscopy.

**SCINTILLATION-COUNTER GAMMA SPECTROSCOPY SYSTEMS** The ORTEC 572A can be used in scintillation-counter spectroscopy systems as shown in Fig. 4.13. The amplifier shaping time constants should be selected in the region of 0.5 to 1  $\mu$ s for NaI or plastic scintillators. For scintillators having longer decay times, longer time constants should be selected.

**X-RAY SPECTROSCOPY USING PROPORTIONAL COUNTERS** Space charge effects in proportional counters, operated at high gas amplification, tend to degrade the resolution capabilities drastically at x-ray energies, even at relatively low counting rates. By using a high-gain low-noise amplifying system and lower gas amplification, these effects can be reduced and a considerable improvement in resolution can be obtained. The block diagram in Fig. 4.14 shows a system of this type. Analysis can be accomplished by simultaneous acquisition of all data on a multichannel analyzer or counting a region of interest in a single-channel analyzer window with a counter and timer or counting ratemeter.

#### 4.10. OTHER EXPERIMENTS

Block diagrams illustrating how the 572A and other ORTEC modules can be used for experimental setups for various other applications are shown in Figs. 4.15 through 4.18.

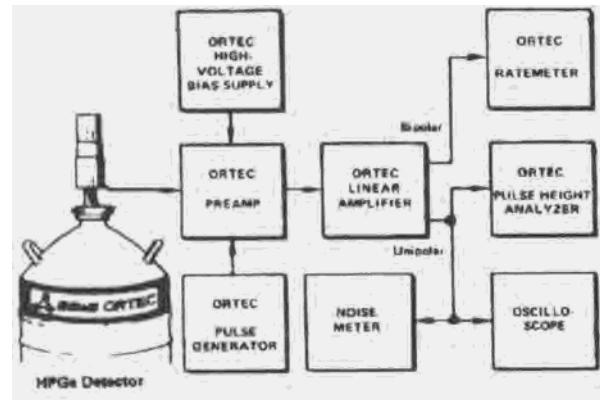

Fig. 4.12. System for High-Resolution Gamma Spectroscopy.

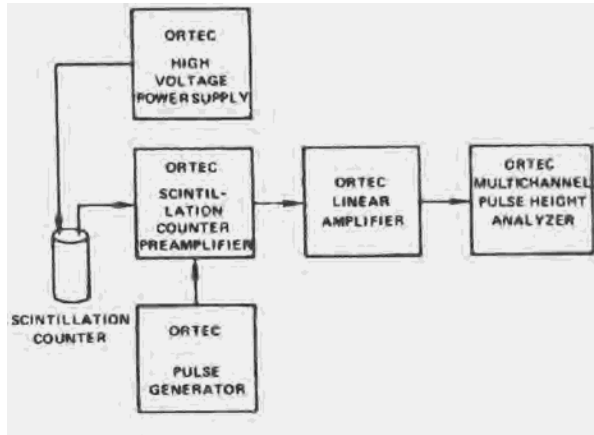

Fig. 4.13. Scintillation-Counter Gamma Spectroscopy System.

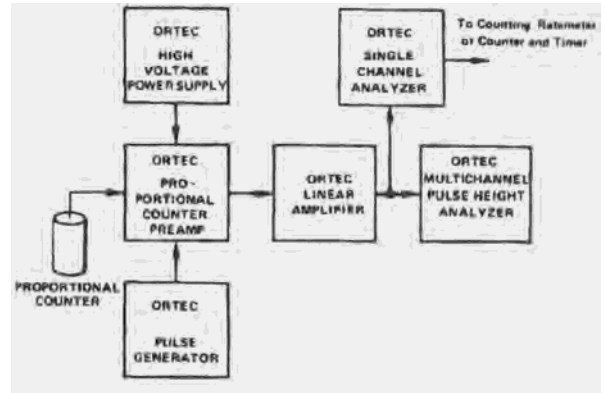

Fig. 4.14. High-Resolution X-Ray Energy Analysis System Using a Proportional Counter.

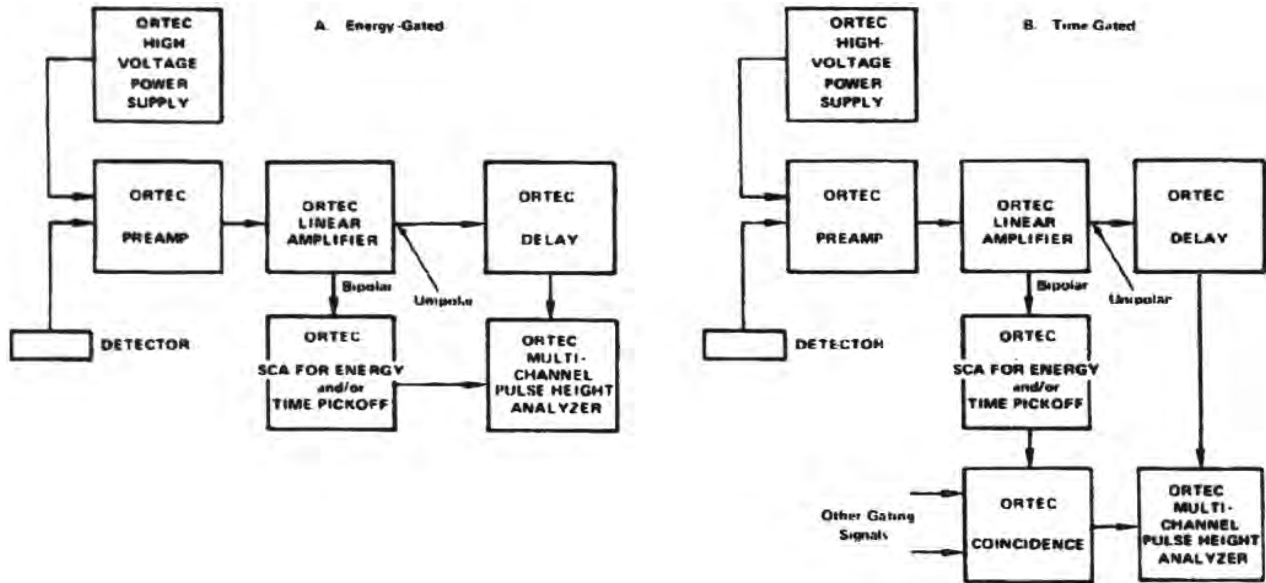

Fig. 4.15. General System Arrangement for Gating Control.

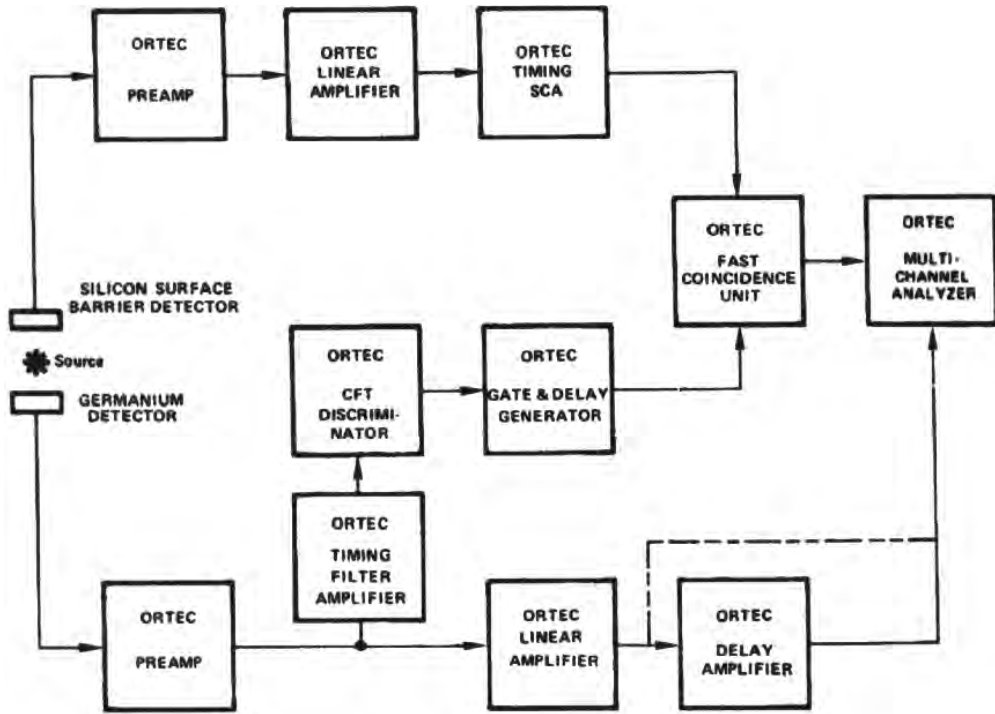

Fig. 4.16. Gamma-Ray Charged-Particle Coincidence Experiment.

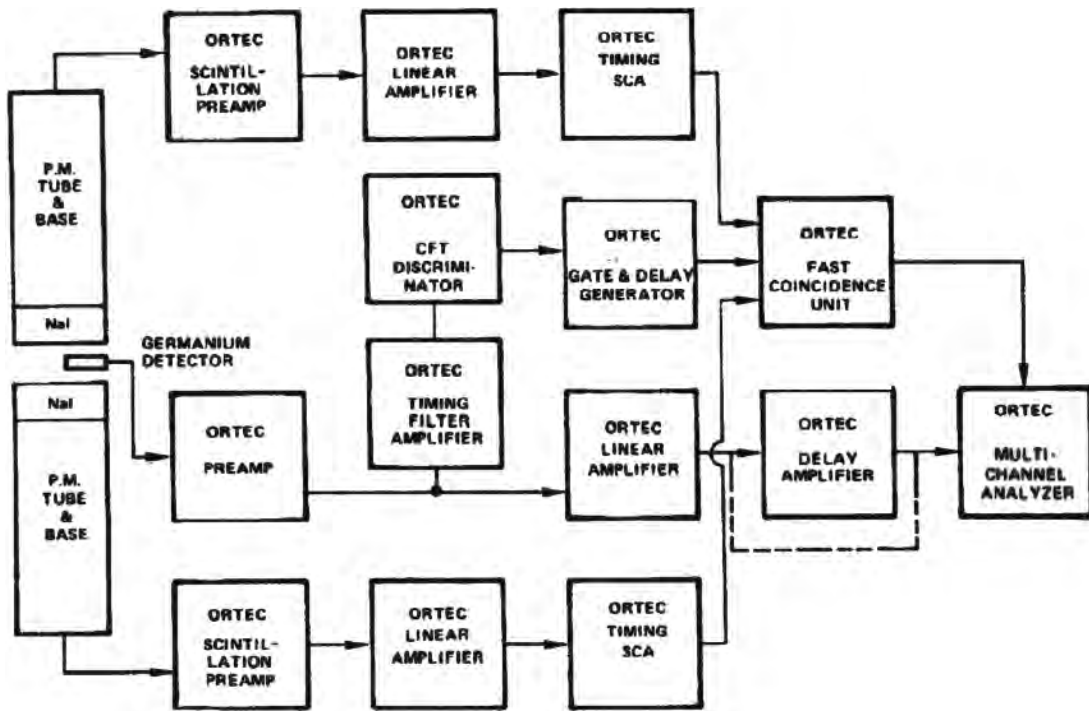

Fig. 4.17. Gamma-Ray Pair Spectrometry.



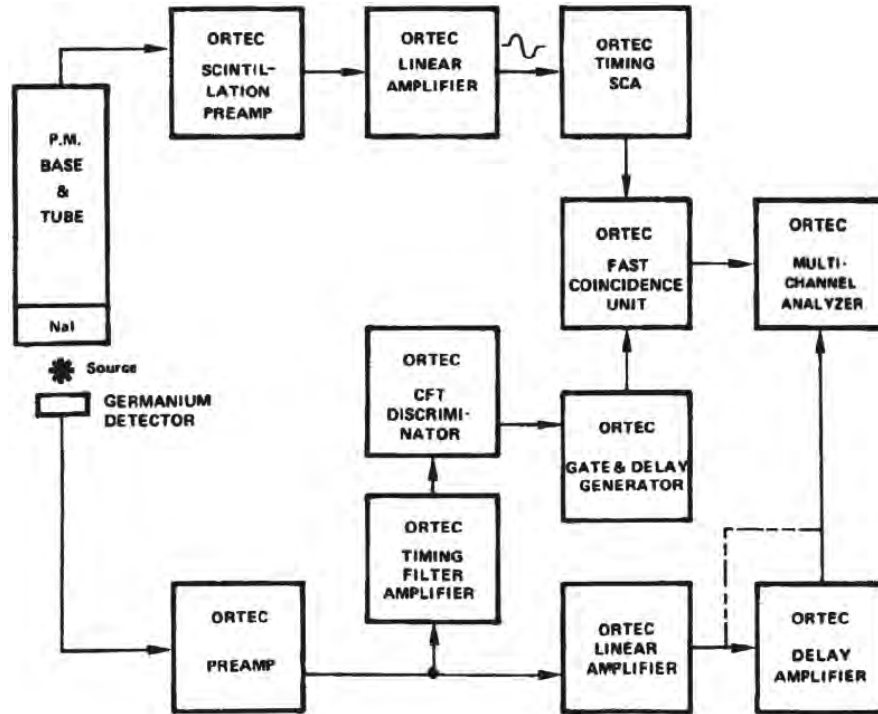

Fig. 4.18. Gamma-Gamma Coincidence Experiment.

## 5. CIRCUIT DESCRIPTION

Figure 5.1 is a block diagram of the instrument. Much of the circuitry in the 572A has been designed to use ORTEC Hybrid circuits. This advanced technology achieves an economical high-density package with high reliability.

Figure 5.2 illustrates the relative timing of the signals in the 572A. The solid-line waveforms show a normal response to a single linear input signal from the preamplifier without any pulse pileup. The broken-line waveforms show the modifications that occur when there is a pileup condition.

The input from the preamplifier is a step change with a very long decay and this is repeated and differentiated at test point TP3. The 572A output that results from this input is shaped, rising to its peak in  $2\tau$ , where  $\tau$  is the selected time constant of 0.5, 1, 2, 3, 6, or 10  $\mu\text{s}$ . The amplifier produces the fast shaped pulse from the same preamplifier input pulse, and this triggers discriminator IC12, set just

above the noise level. The discriminator response triggers the CRM output signal. The discriminator response also triggers the Busy output signal, which has a duration of  $6\tau$ , equal to the duration of the linear output signal. The Inhibit output remains low in the absence of a second pulse from the preamplifier.

Using the broken-line waveforms to show the variations when there is a pulse pileup, the second pulse arrives before the Busy output signal recovers. The linear output signal is distorted by the second pulse. The fast amplifier generates another output that again triggers the discriminator to produce another CRM output pulse and to update the Busy output. Since the bistable for the Inhibit output has been set by the first pulse, the Inhibit output is generated, starting at the response to the second pulse and extending through the  $6\tau$  updated interval of the Busy output.

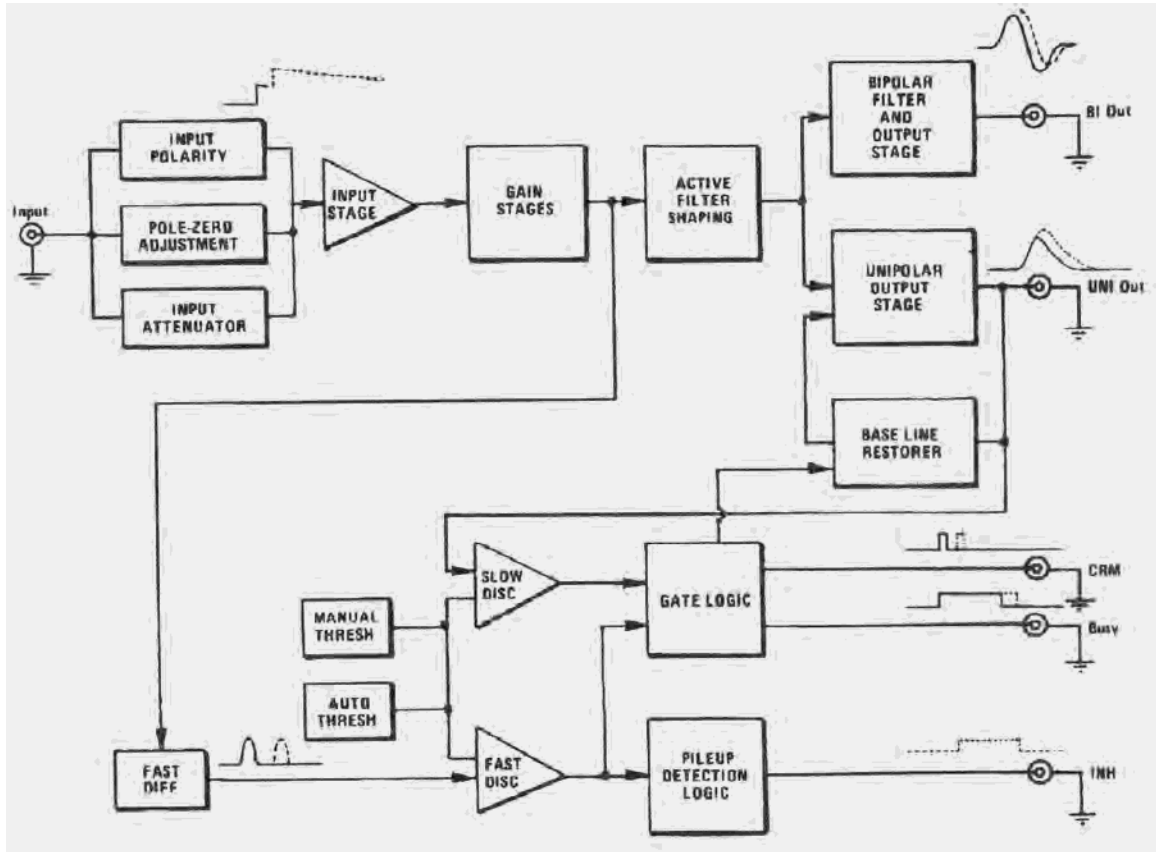

Fig. 5.1. Amplifier Block Diagram.

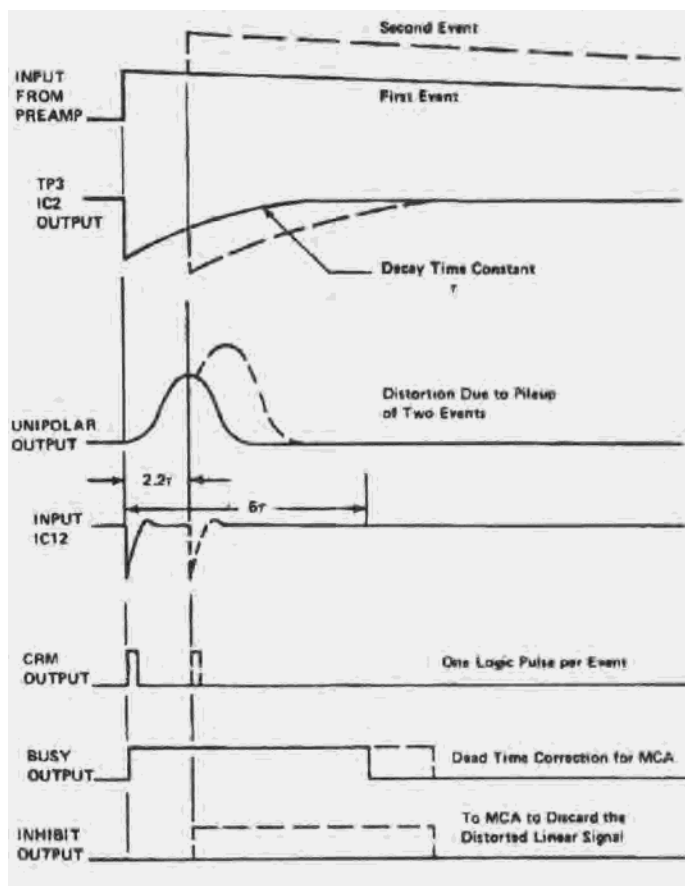

Fig. 5.2. Timing Relations in the 572A Amplifier and Pile-Up Rejector.

## 6. MAINTENANCE

### 6.1. TEST EQUIPMENT REQUIRED

The following test equipment should be utilized to adequately test the specifications of the 572A Spectroscopy Amplifier:

1. ORTEC 419 Precision Pulse Generator or 448 Research Pulser.
2. Tektronix 547 Series Oscilloscope with a type 1A1 plug-in or equivalent.
3. Hewlett-Packard 3400A RMS Voltmeter.

### 6.2. PULSER TEST<sup>1</sup>

Coarse Gain	1K
Gain	1.5

Input Polarity	Positive
Shaping Time Constant	1 $\mu$ s
BLR	PZ Adj
Variable control	Fully CW for 300 mV

a. Connect a positive pulser output to the 572A input and adjust the pulser to obtain +10 V at the 572A Unipolar output. This should require an input pulse of 6.6 mV, using a 100 $\Omega$  terminator at the input.

b. Measure the positive lobe of the Bipolar output. This should also be +10 V.

c. Change the Input polarity switch to Neg and then back to Pos while monitoring the outputs for a polarity inversion.

<sup>1</sup>See IEEE Standards, No. 301-1976.

d. Vary the DC Adj control on the front panel while monitoring the Unipolar output. Ensure that the baseline can be adjusted through a range of +0.1 to -0.1 V. Readjust the control for zero.

e. Recheck the output pulse amplitude and adjust if necessary to set it at +10 V with maximum gain. Decrease the Coarse Gain switch stepwise from 1K to 20 and ensure that the output amplitude changes by the appropriate amount for each step. Return the Coarse Gain switch to 1K.

f. Decrease the Gain control from 1.5 to 0.5 and check to see that the output amplitude decreases by a factor of 3. Return the Gain control to maximum at 1.5.

g. With the Shaping switch set for  $1\ \mu\text{s}$ , measure the time to the peak on the unipolar output pulse; this should be  $2.2\ \mu\text{s}$ , for  $2.2\tau$ . Measure the time to baseline crossover of the bipolar output; this should be  $2.8\ \mu\text{s}$  for  $2.8\tau$ .

h. Change the Shaping switch to 0.5 through  $10\ \mu\text{s}$  in turn. At each setting, check to see that the time to the unipolar peak is  $2.2\tau$  and the time to the bipolar crossover is  $2.8\tau$ . Return the switch to  $1\ \mu\text{s}$ .

**OVERLOAD TESTS** Start with maximum gain,  $\tau=2\ \mu\text{s}$ , and a +10 V output amplitude. Increase the pulser output amplitude by X200 and observe that the unipolar output returns to within 200 mV of the baseline within  $24\ \mu\text{s}$  after the application of a single pulse from the pulser. It will probably be necessary to vary the PZ Adj control on the front panel in order to cancel the pulser pole and minimize the time required for return to the baseline.

Increase the pulser output amplitude to 1000 times the setting that provided the original +10 V output amplitude from the 572A. Observe that the bipolar output returns to within 200 mV of the baseline within  $26\ \mu\text{s}$  after the application of a single pulse from the pulser. It may be necessary to use external control on the pulser to obtain the 6.6-V output required for this test.

**LINEARITY** The integral nonlinearity of the 572A can be measured by the technique shown in Fig. 6.1. In effect, the negative pulser output is subtracted from the positive amplifier output to cause a null point that can be measured with excellent sensitivity. The pulser output must be

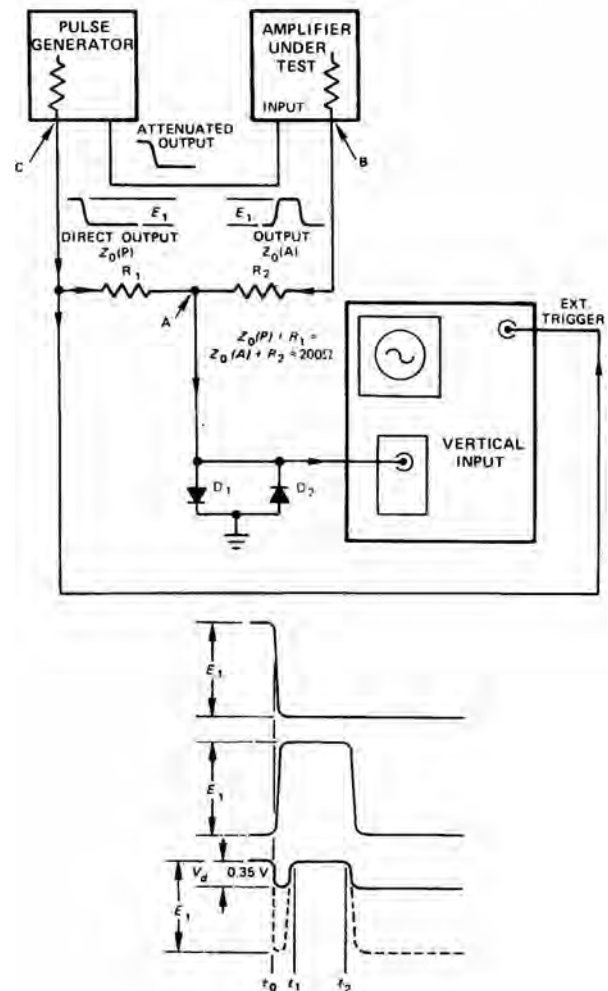

Fig. 6.1. Circuit Used to Measure Nonlinearity.

varied between 0 and 10V, which usually requires an external control source for the pulser. The amplifier gain and the pulser attenuator must be adjusted to measure 0 V at the null point when the pulser output is 10 V. The variation in the null point as the pulser is reduced gradually from 10 V to 0 V is a measure of the nonlinearity. Since the subtraction network also acts as a voltage divider, this variation must be less than

$$(10\ \text{V full scale}) \times (\pm 0.05\% \text{ maximum nonlinearity}) \\ \times (1/2 \text{ for divider network}) = \pm 2.5\ \text{mV}$$

for the maximum null-point variation.

**OUTPUT LOADING** Use the test setup of Fig. 6.1. Adjust the amplifier output to 10 V and observe the null point when the front panel output is terminated in  $100\ \Omega$ . The change should be less than 5 mV.

**NOISE** Measure the noise at the amplifier Unipolar output with maximum amplifier gain and 2  $\mu$ s shaping time. Using a true rms voltmeter, the noise should be less than  $5 \mu\text{V} \times 1500$  (gain), or 7.5 mV.

For an average responding voltmeter, the noise reading would have to be multiplied by 1.13 to calculate the rms noise. The input must be terminated in  $100\Omega$  during the noise measurements

### 6.3. SUGGESTIONS FOR TROUBLESHOOTING

In situations where the 572A is suspected of a malfunction, it is essential to verify such malfunction in terms of simple pulse generator impulses at the input. The 572A must be disconnected from its position in any system, and routine diagnostic analysis performed with a test pulse generator and an oscilloscope. It is imperative that testing not be performed with a source and detector until the amplifier performs satisfactorily with the test pulse generator.

The testing instructions in Section 6.2 and the circuit descriptions in Section 5 should provide assistance in locating the region of trouble and repairing the malfunction. The two side plates can be completely removed from the module to enable oscilloscope and voltmeter observations.

### 6.4. FACTORY REPAIR

This instrument can be returned to the ORTEC factory for service and repair at a nominal cost. Our standard procedure for repair ensures the same quality control and checkout that are used for a new instrument. Always contact Customer Services

at ORTEC, (865) 482-4411, before sending in an instrument for repair to obtain shipping instructions and so that the required Return Authorization Number can be assigned to the unit. This number should be marked on the address label and on the package to ensure prompt attention when the unit reaches the factory.

### 6.5. TABULATED TEST POINT VOLTAGES

The voltages given in Table 6.1 are intended to indicate typical dc levels that can be measured on the printed circuit board. In some cases the circuit will perform satisfactorily even though, due to component tolerances, there may be some voltage measurements that differ slightly from the listed values. Therefore the tabulated values should not be interpreted as absolute voltages but are intended to serve as an aid in troubleshooting.

**Table 6.1. Typical dc Voltages**

Note: All voltages measured with no input signal, with the input terminated in  $100\Omega$ , and all controls set fully clockwise at maximum.

<u>Location</u>	<u>Voltage</u>
TP1	$\pm 5$ mV
TP2	$\pm 30$ mV
TP3	$\pm 20$ mV
TP4	$\pm 20$ mV
TP5	$\pm 30$ mV
TP6	0 to +3.3 V
TP7	$\pm 6$ mV
Q15E	-15 V $\pm 0.8$ V
Q16E	+15 V $\pm 0.8$ V
IC13 pin 2	+5 V $\pm 0.3$ V

**Bin/Module Connector Pin Assignments For Standard  
Nuclear Instrument Modules per DOE/ER-0457T.**

<b>Pin</b>	<b>Function</b>	<b>Pin</b>	<b>Function</b>
1	+3 V	23	Reserved
2	- 3 V	24	Reserved
3	Spare bus	25	Reserved
4	Reserved bus	26	Spare
5	Coaxial	27	Spare
6	Coaxial	*28	+24 V
7	Coaxial	*29	- 24 V
8	200 V dc	30	Spare bus
9	Spare	31	Spare
10	+6 V	32	Spare
11	- 6 V	*33	117 V ac (hot)
12	Reserved bus	*34	Power return ground
13	Spare	35	Reset (Scaler)
14	Spare	36	Gate
15	Reserved	37	Reset (Auxiliary)
*16	+12 V	38	Coaxial
*17	- 12 V	39	Coaxial
18	Spare bus	40	Coaxial
19	Reserved bus	*41	117 V ac (neutral)
20	Spare	*42	High-quality ground
21	Spare	G	Ground guide pin
22	Reserved		

Pins marked (\*) are installed and wired in ORTEC's 4001A and 4001C Modular System Bins.