

Choosing the Right Timing Discriminator for the Application

Fast timing discriminators are useful in two different applications: a) counting narrow pulses at very high counting rates, and b) precisely marking the arrival time of these same pulses. Fast timing discriminators are designed to achieve the best time resolution and the highest counting rates by operating on the fast-rising detector signal. Somewhat worse time resolution at much lower counting rates is available by applying timing single-channel analyzers to the slow output pulse from a linear pulse-shaping amplifier. This slow timing solution is described in the Single-Channel Pulse-Height Analyzer introduction. The fast timing solution is discussed here.

Historically, fast timing discriminators were designed to work with negative pulses from the photomultiplier tube anode fed directly to the discriminator on a terminated 50-Ω coaxial cable. Consequently, a negative input polarity on a 50-Ω impedance has become the standard. Following this convention, "rise time" refers to the time taken to make the transition from 10% to 90% of the pulse amplitude on the leading edge of the pulse, and "fall time" specifies the transition time from 90% to 10% of the amplitude on the trailing edge of the pulse.

Counting

In counting applications, the analog input pulses that cross the discriminator threshold are converted to standard logic pulses at the output of the timing discriminator. These logic pulses can be counted in a counter/timer or in a multichannel scaler. Usually, the discriminator threshold is set just above the noise level, so that all the real events are counted without counting noise pulses. If a narrow band of pulse-heights must be selected for counting, the Model 583B can provide that function with its dual discriminator thresholds.

The maximum permissible counting rate can be restricted by the pulse-pair resolving time of the system. When the inherent width of the detector pulse is not the limiting factor, timing discriminators can offer pulse-pair resolving times in the range of 5 to 65 ns. If dead time losses must be restricted to <10%, a 5-ns pulse-pair resolving time permits average counting rates up to 20 MHz. This same pulse-pair resolving time will handle burst rates up to 200 MHz, provided there is a 5-ns spacing between pulses.

The fast detectors commonly used in single-photon and single-ion counting (photomultiplier tubes, microchannel plate detectors, microchannel plate PMTs, and channeltrons) usually have pulse widths short enough to attain the 5-ns pulse-pair resolution of the fastest discriminators. Other types of detectors, such as scintillation detectors, germanium detectors, and silicon charged-particle detectors, deliver pulse widths that limit the pulse-pair resolving time to much longer values. In most applications the maximum counting rate is limited by the detector and the electronics that precede the timing discriminator because of factors other than pulse-pair resolving time. In such cases, although the pulse-pair resolving time of the timing discriminator does not determine the maximum permissible counting rate for the system, it still affects how closely randomly arriving pulses can occur and yet be recognized as two separate events. This, of course, determines the dead-time losses in a counting experiment.

Dead Time Effects in Counting or Timing

The dead time loss experienced when using fast timing discriminators for either counting or timing measurements is typically controlled by the counting rate and two dominant cascaded dead times, T_e and T_{ne} . T_e is the extending dead time caused by the width of the analog pulse at the noise discriminator threshold. It is an extending dead time because a second analog pulse occurring during a preceding pulse extends the dead time by one pulse width from the second pulse's arrival time, and the second pulse will not be counted. T_e is normally determined by the detector response and any pulse shaping added by an amplifier interposed between the detector and the discriminator. T_{ne} is the longest non-extending dead time following the noise discriminator. Non-extending dead time implies that a pulse arriving during the dead time created by a previous pulse will not be recorded and will not extend the dead time. The minimum value for T_{ne} is the dead time set by the output driver for the discriminator. If the discriminator drives another device which also contributes a non-extending dead time, T_{ne} is assigned the value of the larger of the two non-extending dead times. This latter assignment is an adequately accurate representation of T_{ne} for most practical cases.^{1,2}

For the general case in time spectrometry where $R(t)$ (the instantaneous counting rate of photons or ions at the detector) varies with time, the instantaneous counting rate after dead time losses, $r(t)$, is given by³

Cascaded Dead Times, Variable Counting Rate:

$$r(t) = R(t) \exp\left[-\int_{t-T_e}^t R(t_1) dt_1\right] \left[1 - U(T_{ne}-T_e)\right] \exp\left[-\int_{t-T_{ne}}^{t-T_e} r(t_1) dt_1\right] \quad (2a)$$

¹Jörg W. Müller, *Nucl. Instr. Meth.* 112, (1973), 47-57; Figure 3.

²D.R. Beaman, et al., *J. of Physics E: Sci. Instr.* (1972), 5, 767-776.

³D.A. Gedcke, Development notes and private communication, Nov. 1996.

where time t_1 is distinguished from t only for the purpose of integration over the time interval, and $U(T_{ne}-T_e)$ is a unit step function defined by

$$\begin{aligned} U(T_{ne}-T_e) &= 0 \text{ for } T_{ne} \leq T_e \\ &= 1 \text{ for } T_{ne} > T_e \end{aligned} \quad (2b)$$

In this special case of variable counting rate, $R(t)$ and $r(t)$ can be interpreted as the probability per unit time of observing an event at the input to the detector and at the output of the cascaded dead times, respectively, at the time t . In a practical measurement, a process is stimulated at time $t = 0$, and $R(t)$ represents the probability of events from the process arriving at the detector as a function of time. Because of the cascaded dead times, the probability of recording events as a function of time is given by $r(t)$. To build up a statistically significant time spectrum, one must repeat the stimulation n times (where n is a large number) while summing the resulting time spectra. Generally, this is accomplished in a digital histogramming memory, which has finite time bin widths, Δt . Consequently, the number of counts recorded in a bin at time t is predicted to be

$$q(t) = n r(t) \Delta t \quad (3)$$

The time spectrum recorded in histogram form is described by $q(t)$. The practical application of equations (2) and (3) to time digitizers is explained in the introduction to Counters, Ratemeters, and Multichannel Scalers.

For the simplifying case where $R(t)$ is constant over time, $R(t) = R$ and $r(t) = r$, leading to

Cascaded Dead Times, Constant Counting Rate:

$$r = R \exp[-RT_e] [1 - U(T_{ne}-T_e) r (T_{ne}-T_e)] \quad (4a)$$

$$= \frac{R}{\exp[RT_e] + U(T_{ne}-T_e) R (T_{ne}-T_e)} \quad (4b)$$

If the extending dead time is larger than the non-extending dead time, then the non-extending dead time is irrelevant and equations (2) and (4) become:

Extending Dead Time, Variable Counting Rate:

$$r(t) = R(t) \exp \left[-\int_{t-T_e}^t R(t_1) dt_1 \right] \quad (5)$$

Extending Dead Time, Constant Counting Rate:

$$r = R \exp[-RT_e] \quad (6)$$

Equations (5) and (6) are the equations for a single, extending dead time.

If the extending dead time is negligible compared to the non-extending dead time, then equations (2) and (4) simplify to the relations for a single non-extending dead time:

Non-Extending Dead Time, Variable Counting Rate:

$$r(t) = R(t) \left[1 - \int_{t-T_{ne}}^t r(t_1) dt_1 \right] \quad (7)$$

Non-Extending Dead Time, Constant Counting Rate:

$$r = R [1 - rT_{ne}] \quad (8a)$$

$$= \frac{R}{1 + RT_{ne}} \quad (8b)$$

The above equations allow one to estimate the dead time losses when the counting rate is known (or predicted) and the dead times T_e and T_{ne} have been measured (either by an oscilloscope or by graphing r versus R). These equations can also be used to correct

for the dead time losses if the losses are not excessive. If the dead time losses are less than 15%, the extending, non-extending, and cascaded dead time equations all yield values of $r(t)/R(t)$ that agree within 1%, provided

$$T = T_e + U(T_{ne}-T_e) (T_{ne}-T_e) \quad (9)$$

is substituted for the single dead time in the extending and non-extending equations. This permits considerable simplification of the computation in exchange for a tolerable limit on the dead time loss.

Timing

Marking the arrival time of detected events with precision and consistency is the primary function of a timing discriminator. Achieving the optimum time resolution is important whether the application is time spectroscopy, or simply determining that events from two different detectors occurred simultaneously. The technique for deriving optimum time resolution depends on the type of detector. Therefore, one must choose the right timing discriminator based on the detector characteristics and the intended application. The descriptions and selection charts that follow will guide you to the best choice.

Jitter, Walk and Drift: The Limiting Factors in Timing

Jitter, walk and drift are the three major factors limiting time resolution. These characteristics are most readily described by reference to a simple leading-edge timing discriminator, as illustrated in Fig. 1.

A leading-edge timing discriminator incorporates a simple voltage comparator with its threshold set to the desired voltage (Fig. 1). When the leading edge of the analog pulse crosses this threshold the comparator generates a logic pulse. The logic pulse ends when the trailing edge of the analog pulse crosses the threshold in the opposite direction. The initial transition of the logic pulse is used to mark the arrival time of the analog pulse, and this time corresponds to the threshold crossing on the leading edge of the analog pulse.

In the absence of noise and amplitude variations, the leading-edge discriminator would mark the arrival time of each analog pulse with precision and consistency. However, many systems include a non-negligible level of electronic noise, and this noise causes an uncertainty or jitter in the time at which the analog pulse crosses the discriminator threshold. If e_n is the voltage amplitude of the noise superimposed on the analog pulse, and dV/dt is the slope of the signal when its leading edge crosses the discriminator threshold, the contribution of the noise to the timing jitter is

$$\text{Timing jitter} = e_n / (dV/dt). \quad (10)$$

If the noise cannot be reduced, the minimum timing jitter is obtained by setting the discriminator threshold for the point of maximum slope on the analog pulse. If a low pass filter is applied to reduce the noise by slowing down the pulse rise time, the slope in Equation (10) normally decreases more rapidly than the noise diminishes, and the net result is an increase in timing jitter. Therefore, it is best to preserve the fastest possible rise time from the signal source. For further guidance on choosing the appropriate rise time for the preamplifier and amplifier that precede the timing discriminator, see the introduction on Preamplifiers and Amplifiers. Electronic noise makes a significant contribution to timing jitter with silicon charged-particle detectors, fast photodiodes, Si(Li) detectors, and germanium detectors, and to a somewhat lesser extent with microchannel plates, microchannel plate PMTs, and channeltrons.

With scintillation detectors (scintillators mounted on photomultiplier tubes) the noise contribution is usually negligible, but there is another important contribution to timing jitter: statistical fluctuations in the arrival time of the pulse at the detector output. The optimum solution for this application is discussed below. Germanium detectors also bring a special problem to the timing task, because the rise times of the pulses from these detectors vary over a wide range, and this variation is a dominant source of timing jitter. The special solution for timing with germanium detectors is described later in this section.

"Walk" is the systematic dependence of the time marker on the amplitude of the input pulse. Fig. 1 shows two pulses which have exactly the same shape, but one has twice the amplitude of the other. The higher amplitude pulse crosses the discriminator threshold earlier than the smaller pulse. This is the source of "walk" or time slewing. With a leading-edge timing discriminator, smaller pulses produce an output from the discriminator later than larger pulses do. When observed on an oscilloscope, the timing discriminator output pulses appear to "walk" back and forth on the time axis in response to the variations in the input pulse amplitudes. Obviously, "walk" can seriously degrade the time resolution when a wide range of pulse amplitudes must be processed. The constant-fraction discriminator, ARC timing, and other zero-crossing techniques are highly recommended for eliminating or minimizing "walk".

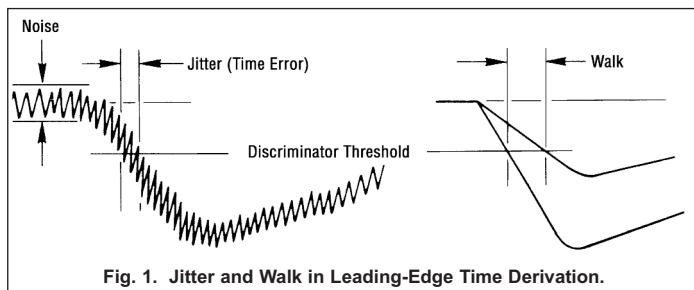

Fig. 1. Jitter and Walk in Leading-Edge Time Derivation.

Drift is the long-term error introduced by component aging and by temperature variations in the discriminator circuits. This is a significant contributor to the timing error only when the temperature changes noticeably during long measurement periods.

Optimum Timing Solutions for Scintillation Detectors

In scintillation/photomultiplier timing systems, jitter is influenced by the generation rate of photons in the scintillator, variations in the photon transit times through the scintillator, the transit time variations of photo electrons from the photocathode to the first dynode, statistical fluctuations in the gains of the individual dynodes, and, to a much smaller degree, the width of the single-electron response of the PMT. Normally, the signal amplitude at the anode output is large enough to make the input noise of the succeeding electronics a negligible contributor. Best time resolutions are obtained from scintillators with small mechanical size, efficient light collection, high light output, and short fluorescence decay times. The photomultiplier should be chosen for high photocathode yield, small photocathode diameter, high first-dynode yield, minimal transit-time spread, and a reasonably narrow single-electron response. With a 14-stage PMT the anode output pulse is usually large enough to be connected directly to the input of the timing discriminator. Eight- or ten-stage PMTs may require some amplification, as described in the introduction to Preamplifiers and Amplifiers.

Leading-Edge Timing

A leading-edge timing discriminator is appropriate when the optimum time resolution is not essential. "Walk" is normally the dominant limitation on time resolution with this method. The rise time of the analog pulse at the discriminator input can be used as a rough estimate of the contribution "walk" will make to the time resolution when a wide range of pulse amplitudes must be processed.

The intrinsic timing jitter of a scintillation detector is inversely proportional to the square root of the pulse amplitude. Consequently, the discriminator threshold can be set to cut off the lowest pulse amplitudes, which have the worst intrinsic jitter. If a very narrow range of pulse amplitudes is being analyzed, the "walk" contribution will be very small, and the discriminator threshold can be set at the level that yields the best time resolution. As shown in Fig. 2(a), the minimum time resolution will typically occur when the threshold is set somewhere between 10% and 40% of the anode pulse-height.

Constant-Fraction Timing

The existence of an optimum triggering fraction for leading-edge timing with scintillation detectors stimulated the design of a circuit that would always trigger at the optimum fraction of the pulse height for any pulse height.^{4,5} This circuit is now known as a Constant-Fraction Discriminator (CFD). An additional benefit of the constant-fraction discriminator is that it essentially eliminates amplitude-dependent time walk for signals having consistent rise times. The net result is optimum time resolution over a wide dynamic range of pulse heights.

The pulse shaping employed in a constant-fraction timing discriminator is shown in Fig. 3. The input signal is split into two parts. One part is attenuated to a fraction f of the original amplitude, and the other part is delayed and inverted. These two signals are subsequently added to form the constant-fraction timing signal. The

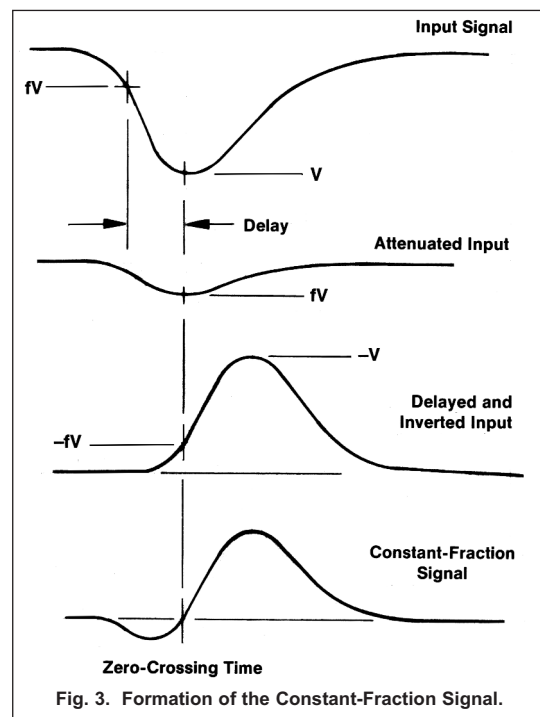
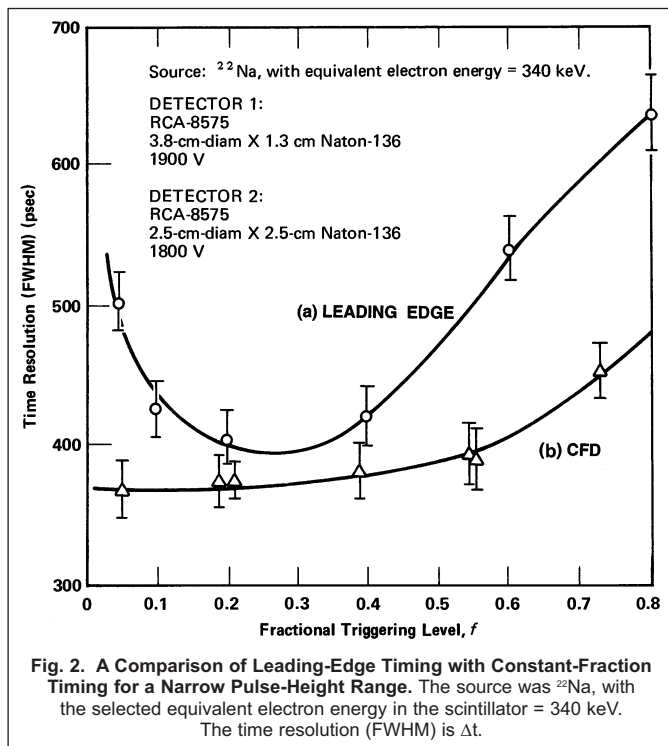

⁴D. A. Gedcke and W. J. McDonald, *Nucl. Instr. and Meth.* 55(2): 377 (1967).

⁵D. A. Gedcke and W. J. McDonald, *Nucl. Instr. and Meth.* 58(2): 253 (1968).

delay is chosen to make the optimum fraction point on the leading edge of the delayed pulse line up with the peak amplitude of the attenuated pulse. Consequently, adding the two signals yields a bipolar signal with a zero-crossing that corresponds to the original point of optimum fraction on the delayed signal. The constant-fraction discriminator incorporates a timing discriminator that triggers on the zero-crossing, thus providing a time marker at the optimum fraction of pulse height. Since the time of zero-crossing is independent of pulse amplitude, the constant-fraction discriminator delivers virtually zero walk. (In practice, a minuscule amount of walk is still experienced for pulse amplitudes below 200 mV, because the zero-crossing comparator requires a finite amount of charge to move its output from the "0" to the "1" state.)

A functional representation of the circuits in a constant-fraction discriminator is shown in Fig. 4. As previously discussed, the input signal is delayed and inverted, and a fraction of the undelayed signal is subtracted from it. A bipolar pulse is generated, and its zero-crossing is detected and used to produce an output logic pulse. A leading-edge arming discriminator provides energy selection and prevents the sensitive zero-crossing comparator from triggering on any noise inherent in the baseline preceding the pulse. The attenuation factor f is the fraction of the pulse height at which timing is desired. Walk and jitter are minimized by proper adjustment of the zero-crossing reference, and by selection of the correct attenuation factor and delay. As shown in Fig. 2(b), **the timing resolution from a constant-fraction discriminator is better than that from a leading-edge timing discriminator**, even for a narrow range of pulse heights. Also, the time resolution with a CFD is remarkably insensitive to the choice of triggering fraction. In the scintillation detector application, a fraction somewhere between 0.2 and 0.4 is a reasonable choice. For further examples of actual performance, see the data sheets on Constant Fraction Discriminators.

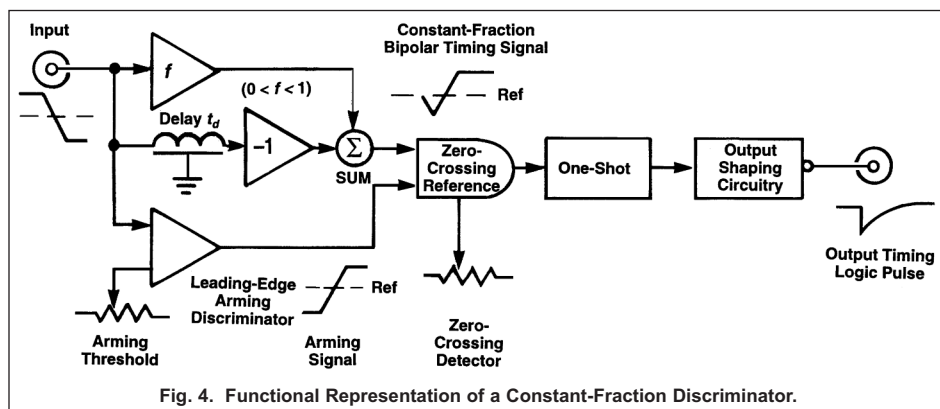

Fig. 4. Functional Representation of a Constant-Fraction Discriminator.

Avoiding Multiple Triggering with Slow Scintillators

The scintillation decay time constant for NaI(Tl) detectors is 230 ns. That is a factor of 20 to 100 times longer than is typical of the fast scintillators that are best for timing. As a result, the last portion of each anode pulse from a NaI(Tl) detector consists of individual, single-photon pulses. If the dead time of the timing discriminator is as short as 10 ns, the discriminator will trigger once on the leading edge of the anode pulse and then multiple times at the end of the anode pulse. This multiple triggering on a single pulse can be prevented by choosing a timing discriminator that allows selecting a non-extending dead time of approximately 1 μ s. The blocking outputs of the Models 583B, and 584 offer that capability. Several other slow scintillators (e.g., CsI(Na), CsI(Tl), and BaF₂) require a similar solution.

Faster scintillators, exhibiting decay times of the order of 5 ns, do not require a special dead time setting.

Timing with Silicon Charged-Particle Detectors

With silicon charged-particle detectors the timing signal is normally accessible at the output of the charge-sensitive preamplifier. Because the signal is fast and small, a fast amplifier must be employed in front of the timing discriminator. The Preamplifier and Amplifier sections of this catalog should be consulted for the proper choice of amplification. It is important to select a low-noise, charge-sensitive preamplifier with minimum rise time, followed by a fast amplifier with a similar rise time.

The timing jitter with this type of detector is dominated by the noise and slope contributions described in Equation (10). Consequently, the best timing resolution can be obtained with a constant-fraction discriminator, whose fraction and delay are selected for triggering at the point of maximum slope on the leading edge of the pulse. Use of the constant-fraction discriminator will

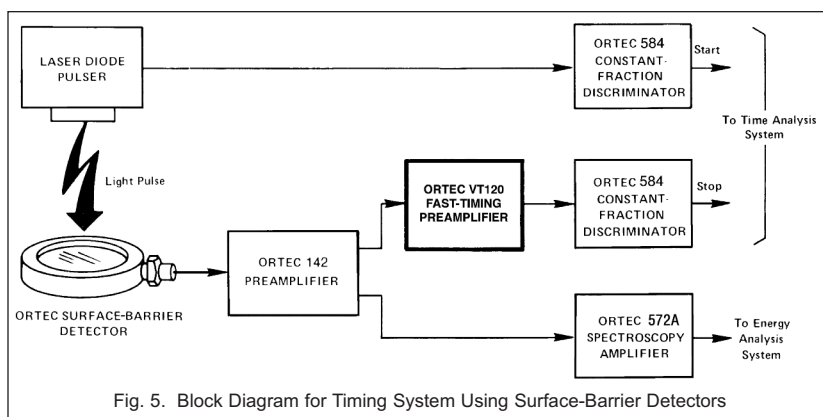

Fig. 5. Block Diagram for Timing System Using Surface-Barrier Detectors

also minimize the walk over a large dynamic range of pulse amplitudes. For practical examples of performance, see the data sheets for the Models 142A/B/C and 142AH.

Data for timing with surface barrier detectors are shown in Figs. 5–7. This information was obtained with a laser diode pulser and standard ORTEC electronics as shown in Fig. 5. Figures 6 and 7 show a typical timing resolution versus detector capacitance for this system.

Picosecond Timing with Microchannel Plates, Microchannel Plate PMTs, and Channeltrons

Microchannel plates and channeltrons are often used for single-ion counting and timing, while microchannel plate photomultiplier tubes find application in single-photon counting and timing. The amplification mechanisms in these detectors are similar to those in a conventional photomultiplier tube, except that the discrete dynodes of the normal PMT are replaced by a continuous dynode formed by a resistive glass tube. The intrinsic contribution to timing jitter in these detectors comes from variations in electron transit times through the device, and fluctuations in secondary-electron yields throughout the glass channel. The microchannel plate structure offers much smaller transit times and proportionately less transit time spread compared to a conventional photomultiplier tube. Consequently, these faster detectors also deliver better time resolution than a conventional PMT.

Microchannel plates, microchannel plate PMTs, and channeltrons produce very small output pulses with ultra-short pulse widths. Rise times are typically 150 to 700 ps, and the pulse widths (FWHM) are equally brief. Therefore, an amplifier with an extremely fast rise time is needed between the detector and the timing discriminator. The Preamplifier section of this catalog should be consulted for the proper choice of amplification. Because of its wide bandwidth, the preamplifier contributes electronic noise to the signal, and this adds to the timing jitter via the mechanism described in Equation (10). Best timing resolution is usually achieved when the amplifier rise time is comparable to the detector rise time.

For single-ion and single-photon timing, the amplitude fluctuations at the detector output are extreme, and one would expect that this situation demands a constant-fraction discriminator to minimize walk. Unfortunately, conventional constant-fraction discriminators do not have adequate bandwidth to properly process signals with rise times as short as 150 ps and pulse widths of the order of 400 ps. **The Model 9307 pico-TIMINGTM Discriminator was developed to solve this problem. It accommodates the ultra-short pulse widths and incorporates a special circuit to eliminate walk (time slewing) over a wide range of pulse amplitudes.** Pairing the Model 9306 1-GHz Preamplifier with the Model 9307 pico-TIMING Discriminator is the best solution for achieving optimum time resolution with microchannel plates, channeltrons, and microchannel plate PMTs. Actual performance is documented in the Model 9307 data sheet. The 9327 is a more convenient solution that combines the 9306 and 9307 functions in one compact preamplifier package.

Single-Photon Timing with Photomultiplier Tubes

The solution for single-photon timing with conventional photomultiplier tubes is similar to that recommended above for microchannel plate PMTs. The significant difference is that conventional photomultiplier tubes have slower rise times (~2 ns) and higher gains. A fast preamplifier is still needed between the detector output and the input to the timing discriminator, but the preamplifier gain can be lower, and the preamplifier rise time can be in the neighborhood of 1 to 3 ns. As a result, the preamplifier input noise normally does not contribute significantly to the timing jitter.

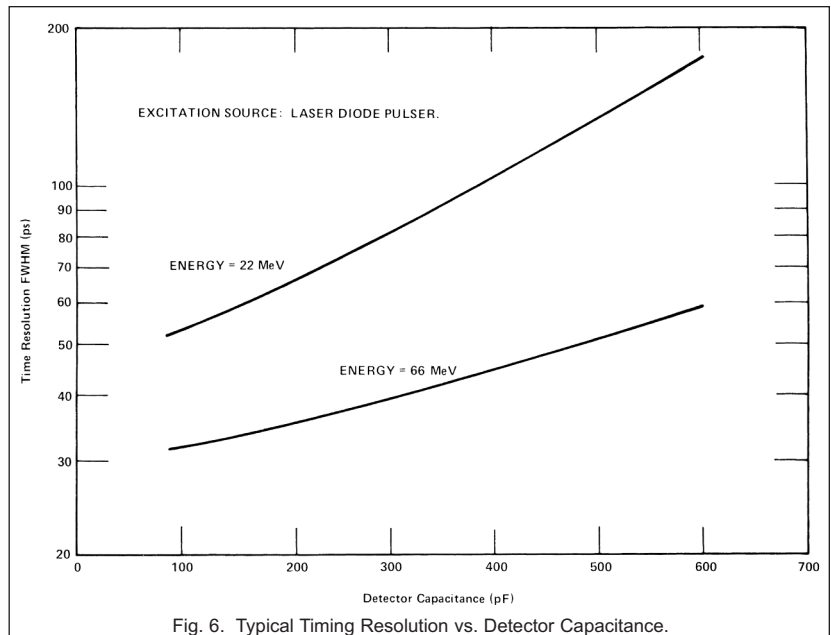

Fig. 6. Typical Timing Resolution vs. Detector Capacitance.

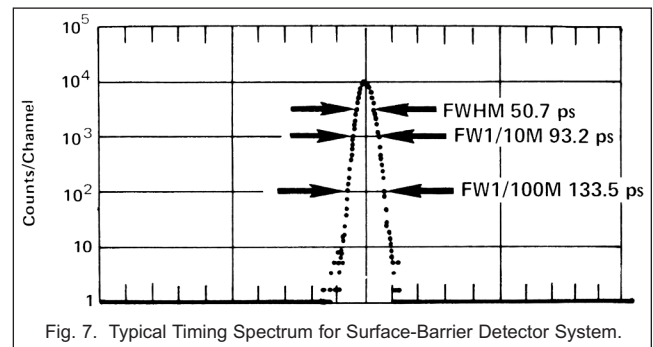

Fig. 7. Typical Timing Spectrum for Surface-Barrier Detector System.

The PMT should be selected for low transit time spread from the cathode to first dynode, high first dynode gain, and a moderately fast single-electron response. For such a PMT, the timing jitter will usually be controlled by (a) the transit time spread from cathode to first dynode, and (b) the amplitude fluctuations caused by variations in secondary electron yields at the first dynode.

In this application, the signal rise time is slow enough that a conventional constant-fraction discriminator will provide optimum time resolution while minimizing the walk from the wide range of pulse heights produced by the detector. Alternatively, the Model 9307 pico-TIMING Discriminator can be used instead of the constant-fraction discriminator or the Model 9327 can be employed.

ARC Timing with Germanium Detectors

With germanium gamma-ray detectors, the best time resolution can be achieved by deriving the timing signal from the output of the charge-sensitive preamplifier. This signal requires amplification before presentation to a timing discriminator, and a Timing Filter Amplifier is the optimum choice for the task. (See the Amplifier introduction.) The rise time of the Timing Filter Amplifier is typically selected to be similar to the preamplifier rise time⁶ (measured with a fast pulser applied to the preamplifier TEST input).

Two factors control the intrinsic time resolution of germanium detectors: (a) variations in the charge collection time, and (b) the noise/slope effect described by Equation (10). The former so overwhelms the latter that the timing technique must be focused on overcoming the charge collection time variations, with the resulting noise/slope contribution simply being tolerated. The top diagram in Fig. 8 depicts the variation in pulse shapes observed at the preamplifier output for a germanium detector. The longest charge collection times (illustrated by pulse C) are caused by gamma rays that produce electron-hole pairs in the detector at a location close to one of the electrodes. In this case, one of the charge carriers has to "drift" the entire distance between electrodes. The minimum charge collection times (pulses A and B) results when the gamma ray interacts in the detector at a position midway between the electrodes. In that situation, the holes and the electrons each drift to their respective electrodes through half of the inter-electrode distance. Consequently, the charge collection time for pulses A and B is about half the charge collection time of pulse C. Gamma rays interacting at other locations in the detector produce charge collection times that are between the limits set by pulses B and C. The longest charge collection time (pulse C) exhibited by a specific germanium detector ranges from 50 ns for the thinnest planar detectors to 600 ns for very large coaxial detectors.

When a leading edge discriminator is used for timing with germanium detectors, the time resolution is about equal to the charge collection time, because of the long and variable charge collection time. Application of a conventional constant-fraction discriminator, as analyzed in Fig. 8, eliminates the walk caused by the difference in A and B pulse heights, but it does not eliminate the timing uncertainty caused by the difference in charge collection times between pulses B and C. The constant-fraction zero-crossing signals for pulses B and C cross the baseline at different times, t_1 and t_2 .

The Amplitude and Risetime Compensated timing technique (ARC timing) minimizes the effect of charge collection time variations from Ge detectors by an unconventional adjustment of a constant-fraction discriminator.^{7,8} The fraction is left at its normal setting (0.2 to 0.3), but the constant-fraction shaping delay is significantly shortened. Instead of selecting the delay per Fig. 3, the rise times of detector pulses are measured at the preamplifier output, and the delay is set to approximately 30% of the minimum rise time. The result is illustrated in Fig. 9. With the shorter delay, the bipolar signals for all three pulses (A, B, and C) cross the baseline at the same time, in spite of different amplitudes or rise times. Thus, the zero-crossing trigger in the modified constant-fraction discriminator delivers amplitude and rise time compensated timing.

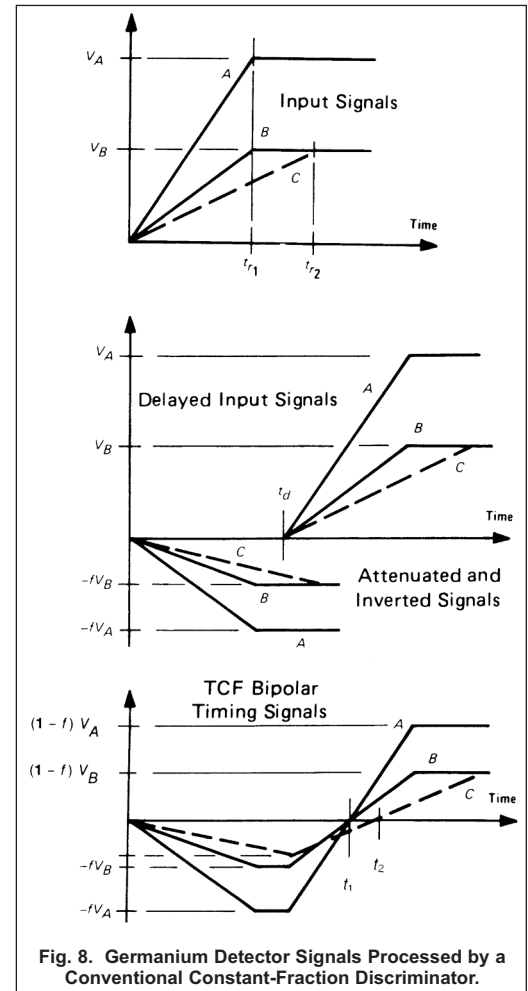

Fig. 8. Germanium Detector Signals Processed by a Conventional Constant-Fraction Discriminator.

⁶T. D. Douglas and C. W. Williams, *IEEE Trans. Nucl. Sci.* **NS-16** (1), 87 (1969).

⁷R. L. Chase, *Rev. Sci. Instrum.* **39**(9), 1318 (1968).

⁸Z. H. Cho and R. L. Chase, *Nucl. Instrum. Methods* **98**, 335-347 (1972).

Theoretically, ARC timing generates a timing marker that is independent of amplitude and rise time, provided each pulse has a constant slope throughout its leading edge. Real pulses from planar Ge detectors exhibit constant slope only for the pulses with either minimum or maximum rise time. Pulses with intermediate rise times start with the maximum slope, but abruptly lower their slope by a factor of two when the charge carrier that experiences the shorter drift distance reaches its electrode. ARC timing will not completely compensate for the rise time if the slope changes before the time of zero crossing. The shaping delay is purposely kept short to minimize the sensitivity to abrupt slope changes.

Because of their coaxial structure, large Ge detectors produce pulse shapes that deviate somewhat from the linear rise depicted in Fig. 9. The shape of each pulse depends on where the hole-electron pairs were created in the detector.⁹ On a pulse-to-pulse basis, the shape of the leading edge varies from convex to concave, and many pulses are a mixture of these two shapes. As a result of this deviation from the ideal linear rise, ARC timing does not provide perfect compensation for the rise time variations on coaxial Ge detectors. Still, it is the most productive method for minimizing the dominant timing errors, which are caused by charge collection time variations and amplitude swings.

ARC Timing with Slow Rise Time Rejection

State-of-the-art manufacturing techniques have virtually eliminated exceptionally slow rise times in germanium detectors. However, one may still encounter older detectors that produce pulses with rise times much longer than those described above. Usually, these pulses are caused by gamma rays interacting in regions of the detector that have a weak field and slow charge collection. When the ARC timing method is applied to these pulses, the zero-crossing detector can trigger before the leading-edge arming discriminator (Fig. 4). As a result, the timing output of the constant-fraction discriminator will correspond to the leading-edge trigger instead of the zero-crossing detection. These events have excessive "walk" associated with them, and cause a long tail on the timing peak (Fig. 10). Pulses with normal rise times, but with amplitudes close to the leading-edge arming discriminator threshold, cause similar behavior.

Some constant-fraction discriminators have a Slow Rise Time rejection mode (SRT) that can be used to reject these errant events, thus improving the symmetry of the peak in the time spectrum¹⁰ (Fig. 10). The SRT mode blocks the timing output when the zero-crossing detector triggers before the leading-edge arming discriminator. Although the SRT mode improves the shape of the timing peak, it does so by rejecting events that would appear in the full-energy peak of the analyzed energy spectrum. Thus, detection efficiency can be compromised in favor of time resolution, or vice versa. The SRT mode can be enabled or disabled on the ORTEC modules that offer this feature.

For practical examples of the time resolution obtained with ARC timing on germanium detectors, see the data sheets on the Models 474 and 579.

Optimization of Timing Discriminators

Several controls are available on timing discriminators to optimize performance. Common to all discriminators is the Threshold adjustment. All ORTEC discriminators have front-panel adjustable potentiometers for threshold control, except those that incorporate a computer-controlled DAC. The Threshold should be adjusted above the noise to reduce false triggering. In some timing applications, it may be desirable to raise the Threshold and eliminate the lower pulse amplitudes which typically produce worse timing resolution.

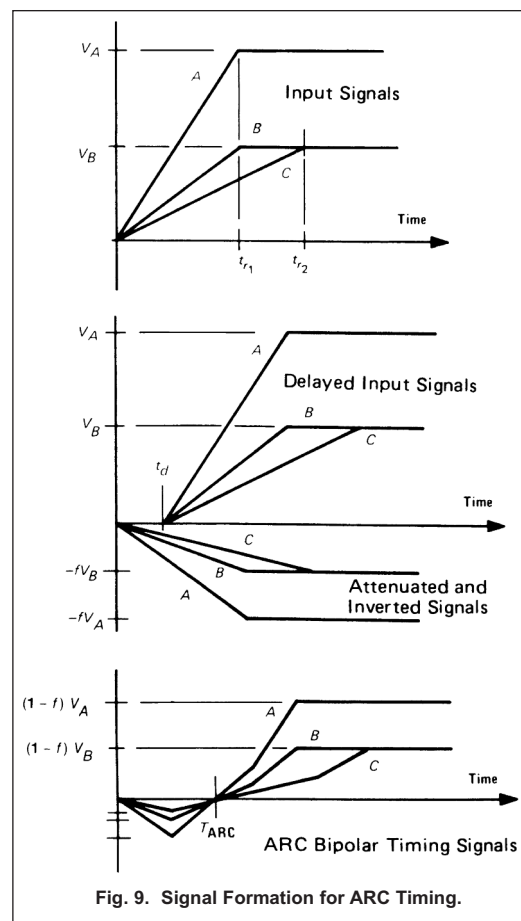

Fig. 9. Signal Formation for ARC Timing.

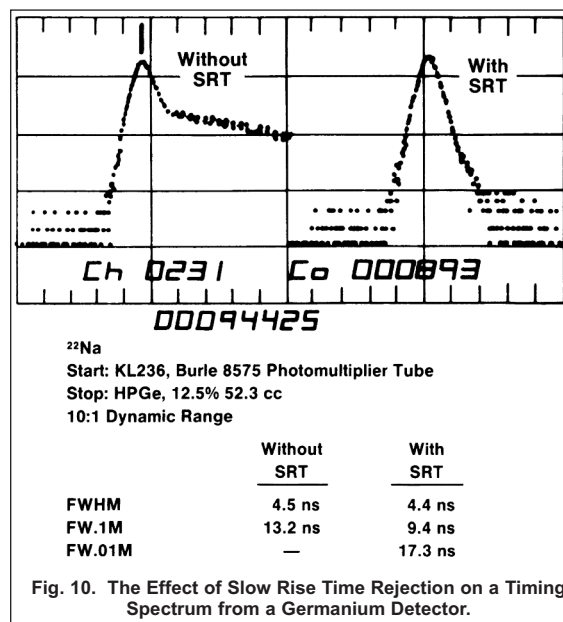

Fig. 10. The Effect of Slow Rise Time Rejection on a Timing Spectrum from a Germanium Detector.

⁹E. Sakai, *IEEE Trans. Nucl. Sci.* **NS-15** (3), 310 (1968).

¹⁰M. Bedwell and T. J. Paulus, *IEEE Trans. Nucl. Sci.* **NS-23** (1), 234 (1976).

Constant-fraction discriminators, used either in the constant-fraction or the ARC timing mode, have additional adjustments. Of principal importance is the delay selection. Various models have external cable delays, internal cable delays, or internal lumped-constant delay lines. Internal delays are the most convenient, but external cable delays allow better optimization of the timing performance in exacting experiments.

When using detectors having a constant rise-time signal, the delay is nominally equal to the time taken by the detector signal to rise from the intended triggering fraction (e.g., 20%) to 100% of its maximum amplitude. As the selection of the delay is critical, experimentation is appropriate to determine the optimum value. For example, a 36-cm delay cable was found to be optimum when using a Hamamatsu R1332 or Burle 8850 PMT with the Model 583B CFD and a 12.9 cm³ BC418 scintillator.

Selection of the delay for germanium detectors is more difficult and can best be determined experimentally. In general, the larger the germanium detector, the longer the delay. A 10% HPGe detector may require a 20-ns delay, while a 70% relative efficiency detector may require a 35-ns delay. However, there is still a large spread in optimum delay, even among detectors of similar size. Often a delay unit consisting of various lengths of high-quality coaxial cable is used to set the delay for a germanium detector. When using an external delay unit, its insertion delay as well as the delay of the interconnecting cables must be counted as part of the delay.

The optimum delay when timing with silicon charged-particle detectors is dependent on the preamplifier. Generally, the charge collection time for this type of detector is much faster than the rise time of the preamplifier. Because the preamplifier output delivers the signal to the constant-fraction discriminator, the proper delay is based on the rise time of the preamplifier output signal. If additional amplification follows the preamplifier, the delay must be appropriate for the signal fed to the constant-fraction discriminator.

The final critical adjustment on a constant-fraction discriminator is the Walk Adjustment. Referring to Fig. 4, the Walk Adjustment corresponds to setting the Zero-Crossing Reference. Most units have the Walk Adjustment available on the front panel, while in a few units the walk must be adjusted using a printed wiring board potentiometer.

Most constant-fraction discriminators have a special Monitor output, which can be used to optimize the walk adjustment. The constant-fraction discriminator is connected as shown in Fig. 11 when its input is taken from an actual detector and its output is used to trigger a fast oscilloscope. The Monitor output signal is delayed a few nanoseconds and connected to a 50-Ω input on the oscilloscope. The Monitor signal will generally be one of two types. ORTEC Model 583B has a well-shaped monitor signal like that shown in Fig. 12a. Other discriminators provide a truncated monitor signal from the zero-crossing detector output like that shown in Fig. 12b. The well-formed Monitor signal is an output from the transformer pulse shaping circuit used in Model 583B. In Fig. 12a, the walk adjustment is optimized when all pulse amplitudes cross through the baseline at the same time. In Fig. 12b, the walk adjustment is optimized when the noise on the baseline between pulses is centered between the high and low logic levels of the zero-crossing detector output. A further fine tuning of the walk adjustment can be achieved by minimizing the peak width observed in the time spectrum from a time-to-amplitude converter.

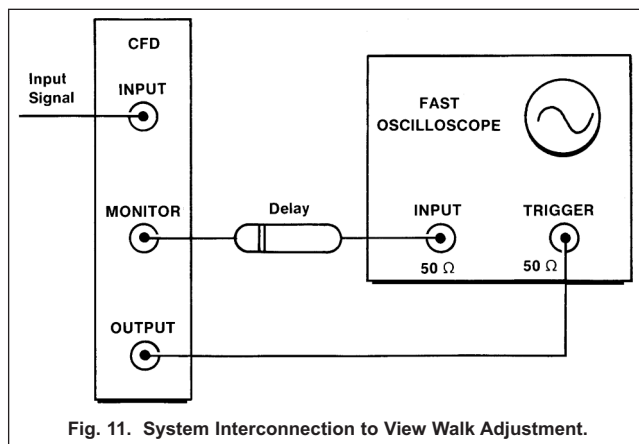
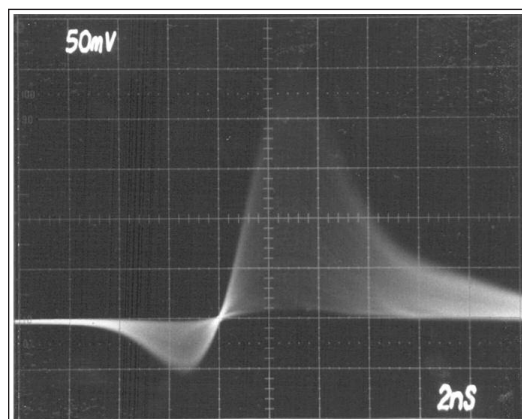
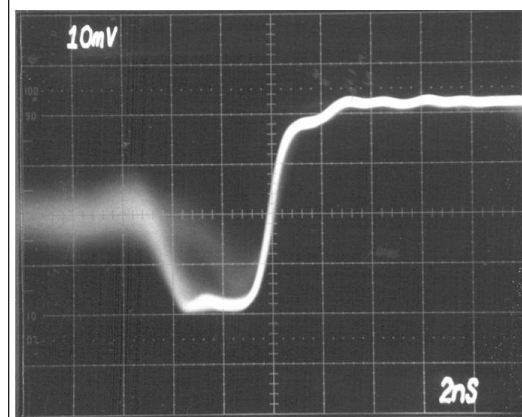

Fig. 11. System Interconnection to View Walk Adjustment.



(a)



(b)

Fig. 12. Monitor Signals when Triggered by the Constant-Fraction Discriminator Output Signal for (a) Passive Pulse Shaping and (b) for Active Pulse Shaping.

Specifications subject to change
102221